

# *Leica TPS800 Series*



***User Manual***

***Version 1.0***

***English***

***Leica***  
**Geosystems**

---

## ***Electronical Total Station***

**Congratulations on the purchase of a TPS800 series instrument.**



This manual contains important safety directions as well as instructions for setting up the product and operating it. Refer to "Safety Directions" for further information.



Read carefully through the User Manual before you switch on the product.

---

## ***Product identification***

The model and the serial number of your product are indicated on the type plate.



Enter the model and serial number in your manual and always refer to this information when you need to contact your agency or Leica Geosystems authorized service workshop.

Type: \_\_\_\_\_ Serial no.: \_\_\_\_\_

---

## ***Symbols***

The symbols used in this manual have the following meanings:

Type	Description
 <b>Danger</b>	Indicates an imminently hazardous situation which, if not avoided, will result in death or serious injury.
 <b>Warning</b>	Indicates a potentially hazardous situation or an unintended use which, if not avoided, could result in death or serious injury.
 <b>Caution</b>	Indicates a potentially hazardous situation or an unintended use which, if not avoided, may result in minor or moderate injury and/or appreciable material, financial and environmental damage.

Type	Description
	Important paragraphs which must be adhered to in practice as they enable the product to be used in a technically correct and efficient manner.

---

## ***Trademarks***

- Windows (registered trademark of Microsoft Corporation).
- All other trademarks are the property of their respective owners.

## ***Contents - Overview***

<b>Introduction</b> .....	8	<b>COMM Parameters</b> .....	113
<b>Operating the Instrument</b> .....	16	<b>Data Transfer</b> .....	114
<b>Measuring Preparation / Setting up</b> ..	24	<b>System Info</b> .....	115
<b>FNC Key</b> .....	37	<b>Care and Transport</b> .....	116
<b>Programs</b> .....	44	<b>Safety Directions</b> .....	119
<b>Settings</b> .....	90	<b>Technical Data</b> .....	141
<b>EDM Settings</b> .....	95	<b>Index</b> .....	152
<b>File Management</b> .....	100		
<b>Start-up sequence</b> .....	103		
<b>Check &amp; Adjust</b> .....	104		

# Contents

<b>Introduction</b> .....	8	Menu tree.....	23
Important parts.....	9	<b>Measuring Preparation / Setting up</b> ..	24
Technical terms and abbreviations .....	10	Unpacking.....	24
Area of applicability.....	13	Batteries.....	25
PC Program Package		Setting up the tripod.....	27
Leica Geo Office Tools (LGO-Tools) .....	13	Centring with laser plummet, coarse level-up .....	29
Installation on the PC .....	13	Fine tuning in the horizontal with the electronic bubble .....	30
Program content.....	13	Laser intensity.....	31
Power Supply.....	15	Hints for positioning .....	31
<b>Operating the Instrument</b> .....	16	Input mode .....	32
Keypad .....	16	Edit characters .....	32
Fixed keys .....	17	Erasing characters .....	32
Trigger key.....	17	Inserting characters.....	32
Distance measurement .....	18	Pointsearch .....	34
Softkeys .....	21	Wildcard search.....	35
Symbols .....	22	Measuring.....	36
Status symbol "EDM type" .....	22	<b>FNC Key</b> .....	37
Status symbol "Battery capacity" .....	22	Light On /Off.....	37
Status symbol "Compensator" .....	22		
Status symbol "Offset" .....	22		
Status symbol "Character Input" .....	22		

Level/Plummet .....	37	Tie Distance .....	71
IR/ RL Toggle .....	37	Area (plan) .....	73
Laser Pointer .....	37	Remote Height .....	74
Free-Coding .....	37	Construction .....	75
Units .....	37	2D-Road (optional) .....	77
Delete Last Record .....	38	COGO (optional) .....	81
Check Tie .....	38	Coding .....	86
Tracking .....	39	Quick Code .....	88
Target Offset .....	39	<b>Settings</b> .....	90
Main Settings .....	40	<b>EDM Settings</b> .....	95
Height Transfer .....	41	<b>File Management</b> .....	100
Hidden Point .....	42	<b>Start-up sequence</b> .....	103
<b>Programs</b> .....	44	<b>Check &amp; Adjust</b> .....	104
Application pre-settings .....	44	Line-of-sight error (Hz-collimation) .....	105
Setting job .....	44	V-Index (Vertical index error) .....	105
Setting Station .....	45	Tripod .....	108
Orientation .....	46	Circular level .....	108
Applications .....	50	Circular level on the tribrach .....	109
Introduction .....	50	Laser plummet .....	109
Surveying .....	51	Reflectorless EDM .....	110
Stake out .....	52		
Free Station .....	54		
Reference Line/Arc .....	60		

<b>COMM Parameters</b> .....	113	Adverse uses .....	119
<b>Data Transfer</b> .....	114	Limits of Use .....	120
<b>System Info</b> .....	115	Responsibilities .....	121
<b>Care and Transport</b> .....	116	International Warranty, Software Licence Agreement .....	122
Transport .....	116	Hazards of use .....	123
Transport in the field .....	116	Laser Classification .....	127
Transport in a road vehicle .....	116	Integrated Distancer, Invisible Laser .....	127
Shipping .....	116	Integrated Distancer, Visible Laser .....	129
Shipping, transport of batteries .....	116	Electronic Guide Light EGL .....	133
Field adjustment .....	116	Laser plummet .....	135
<b>Storage</b> .....	117	Electromagnetic Compatibility EMC .....	138
Product .....	117	FCC Statement, Applicable in U.S. ....	139
Field adjustment .....	117	<b>Technical Data</b> .....	141
Batteries .....	117	Atmospheric correction .....	147
<b>Cleaning and Drying</b> .....	118	Reduction formulae .....	150
Objective, eyepiece and prisms .....	118	<b>Index</b> .....	152
Fogging of prisms .....	118		
Damp products .....	118		
Cables and plugs .....	118		
<b>Safety Directions</b> .....	119		
Intended Use .....	119		
Permitted use .....	119		

## ***Introduction***

The Leica Geosystems TPS800 is a high-quality electronic Total Station designed for the construction site.

Its innovative technology makes the daily surveying jobs easier.

The instrument is ideally suited for simple construction surveys and stake out tasks.

The easy operation of the instrument functions can be learned without problems in no time.

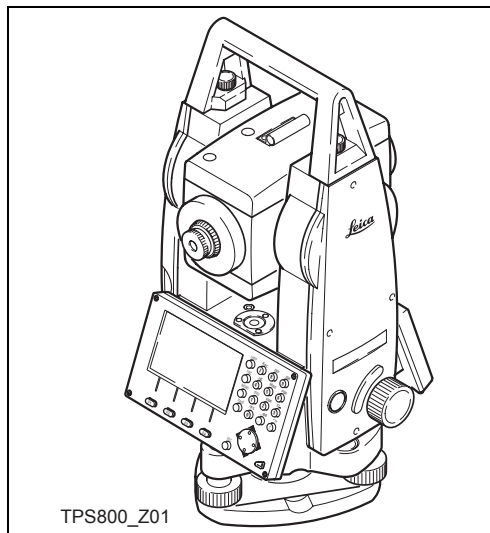

TPS800\_Z01

## Important parts

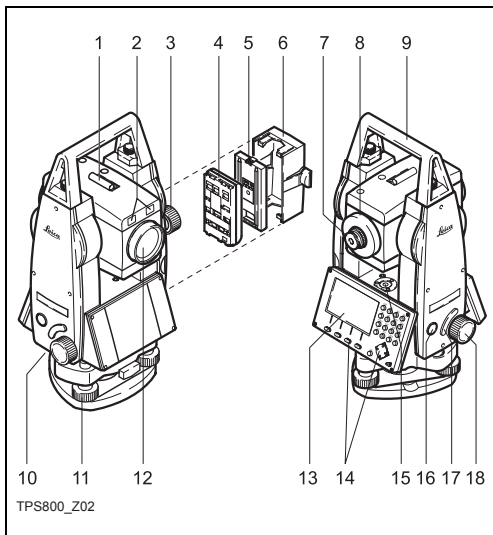

- 1) Optical sight
- 2) Integrated guide light EGL (optional)
- 3) Vertical drive
- 4) Battery
- 5) Battery stand for GEB111
- 6) Battery cover
- 7) Eyepiece; focussing graticule
- 8) Focussing telescope image
- 9) Detachable carrying handle with mounting screws
- 10) Serial interface RS232
- 11) Foot screw
- 12) Objective with integrated Electronic Distance Measurement (EDM); Beam exit
- 13) Display
- 14) Keyboard
- 15) Circular level
- 16) On/Off key
- 17) Trigger key
- 18) Horizontal drive

## Technical terms and abbreviations

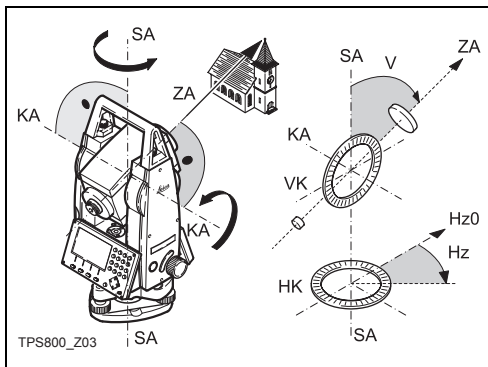

### **ZA = Line of sight / collimation axis**

Telescope axis = line from the reticle to the centre of the objective.

### **SA = Standing axis**

Vertical rotation axis of the telescope.

### **KA = Tilting axis**

Horizontal rotation axis of the telescope (Trunion axis).

### **V = Vertical angle / zenith angle**

### **VK = Vertical circle**

With coded circular division for reading the V-angle.

### **Hz = Horizontal direction**

### **HK = Horizontal circle**

With coded circular division for reading the Hz-angle.

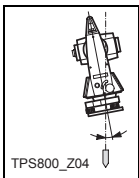

### Standing axis inclination

Angle between plumb line and standing axis. Standing axis tilt is not an instrument error and is not eliminated by measuring in both faces. Any possible influence it may have on the Hz-direction resp. V-angle is eliminated by the dual axis compensator.

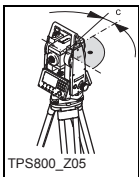

### Line-of-sight error (Hz-collimation)

The line-of-sight error is the deviation from the perpendicular between tilting axis and line-of-sight. This could be eliminated by measuring in both faces.

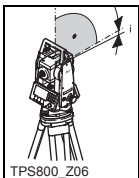

### V-Index (Vertical index error)

With horizontal line-of-sight the V-circle reading should be exactly  $90^\circ$  (100gon). The deviation from this value is termed V-index (i).

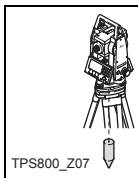

### Plumb line / Compensator

Direction of gravity. The compensator defines the plumb line within the instrument.

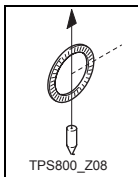

### Zenith

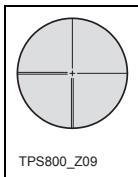

Point on the plumb line above the observer.

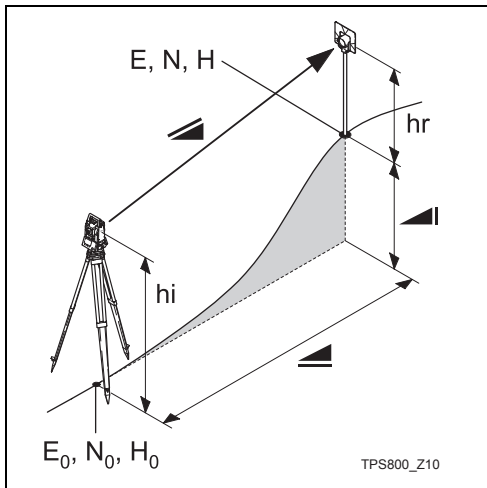

### Reticle

Glass plate within the telescope with reticle.



-  Indicated meteorological corrected slope distance between instrument tilting axis and centre of prism/laser dot (TCR).
-  Indicated meteorological corrected horizontal distance.
-  Height difference between station and target point.
- $h_r$  Reflector height above ground
- $h_i$  Instrument height above ground
- $E_0$  Station coordinate (Easting)
- $N_0$  Station coordinate (Northing)
- $H_0$  Station height
- $E$  Easting of target point
- $N$  Northing of target point
- $H$  Height of target point

---

## ***Area of applicability***

This User Manual is valid for all instruments of the TPS800 Series.

TC Instruments are equipped with an invisible infrared EDM and TCR Instruments with a visible red laser for reflectorless measuring.

Sections only valid for TCR instruments are marked accordingly.

---

## ***PC Program Package***

### ***Leica Geo Office Tools (LGO-Tools)***

The program package LGO-Tools is used for the data exchange between the Total Station and the PC. It contains several auxiliary programs in order to support your use of the Instrument.

### ***Installation on the PC***

The installation program can be found on the CD-ROM supplied. Please note that LGO-Tools can only be installed on computers with MS Windows 98, 2000 or XP operating systems.



Any previous versions of LGO-Tools on your computer must be uninstalled first before installing the new version.

For the installation call program "**setup.exe**" in the directory **\\LGO-Tools** on the CD-ROM and follow the input instructions of the installation program.

### ***Program content***

After successful installation the following programs appear:

## Tools

- **Data Exchange Manager**  
For data exchange of coordinates, measurements, codelists and output formats between instrument and PC.
  - **Coordinate Editor**  
Import/Export as well as creating and processing of coordinate files.
  - **Codelist Manager**  
For creating and processing of codelists.
  - **Software Upload**  
For loading/deleting system software, application programs and EDM-software as well as system/application texts.
-  Before the Software Upload, always insert a charged battery into the instrument.

- **Format Manager**  
For creating of own, special formatted data output files.
  - **Configuration Manager**  
Import/Export as well as creating of instrument configuration.
-  For more informationen about LGO-Tools refer to the comprehensive Online Help.

---

## Power Supply

Use the Leica Geosystems batteries, chargers and accessories or accessories recommended by Leica Geosystems to ensure the correct functionality of the instrument.

Power for the instrument can be supplied either internally or externally. An external battery is connected to the instrument using a LEMO cable.

- **Internal battery:**  
One GEB111 or 121 battery fit in the battery compartment.
- **External battery:**  
One GEB171 battery connected via cable.

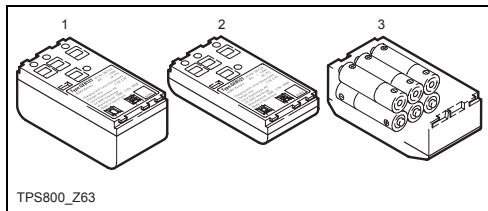

- 1 GEB121
- 2 GEB111
- 3 Single cells in the battery adapter GAD39

Your Leica Geosystems instrument is powered by rechargeable plug-in batteries. For this product, we recommend the basic battery (GEB111) or the Pro battery (GEB121). Optionally six single cells can be used with the GAD39 battery adapter.

Six single cell batteries (1.5 V each) supply 9 Volts. The voltmeter on the instrument is designed for a voltage of 6 Volts (GEB111/ GEB121).

 The battery charge is not displayed correctly when using single cells. Use the single cells with the battery adapter as emergency power supply. The advantage of the single cells is in a lower rate of discharge even over long periods.

# Operating the Instrument

The on / off key is located on the side cover of the Total Station.

 All shown displays are examples. It is possible that local software versions are different to the basic version.

## Keypad

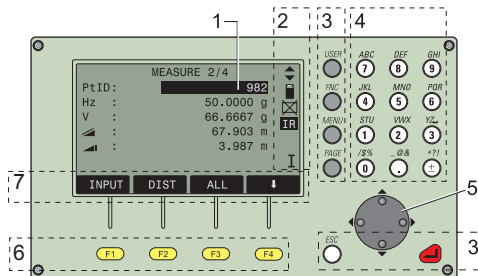

TPS800\_Z11

- 1) Focus  
Actively measured field.
- 2) Symbols
- 3) Fixed keys  
Keys with firmly assigned functions.
- 4) Alphanumeric keys
- 5) Navigation keys  
Control of input bar in edit and input mode or control of focus bar.
- 6) Function keys  
Are assigned the variable functions displayed at the bottom of the screen.
- 7) Softkey bar  
Displays functions that can be called up with the function keys.

## Fixed keys

- [PAGE] Scrolls to next page when a dialogue-consists of several pages.
- [MENU] Accesses programs, settings, the data manager, adjustments, communications parameters, system information and data transfer.
- [USER] Key, programmable with function from the FNC menu.
- [FNC] Quick-access to measurement-supporting functions.
- [ESC] Quit a dialog or the edit mode with activation of the "previous" value. Return to next higher level.
-  Confirm an input; continue to the next field.

---

## Trigger key

The measurement trigger (see "Important parts"; index 17) has three settings (ALL, DIST, OFF). The key can be activated in the configuration menu.

 At menus with multiple entries a shortcut number is shown on the right of each entry. Using this number allowing a direct start, without paging.

---

## ***Distance measurement***

A laser distancer (EDM) is incorporated into the instruments of the TPS800 series.

In all versions, the distance can be determined by using an invisible infrared beam which emerges coaxially from the telescope objective.

 **Measurements to strongly reflecting targets such as to traffic lights in infrared mode without prism should be avoided. The measured distances may be wrong or inaccurate.**

For applications without reflector, the TCR-version also use a **visible red laser beam** which emerges in the same manner. A special arrangement of the EDM, and appropriate arrangement of the beam paths, enable ranges of over five kilometres to be attained with standard prisms.

Miniprisms, 360° reflectors and reflector tapes can also be used, and measurement is also possible without a reflector.

 **When a distance measurement is triggered, the EDM measures to the object which is in the beam path at that moment.**

If e.g. people, cars, animals, swaying branches, etc. cross the laser beam while a measurement is being taken, a fraction of the laser beam is reflected and may lead to incorrect distance values.

Avoid interrupting the measuring beam while taking reflectorless measurements or measurements using reflective foils. Measurements to prism reflectors are only critical if an object crosses the measuring beam at a distance of 0 to 30m and the distance to be measured is more than 300m.

In practice, because the measuring time is very short, the user can always find a way of avoiding these critical situations.

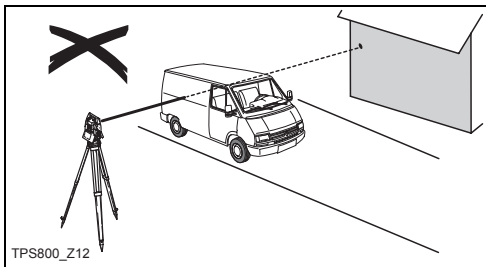

Incorrect result

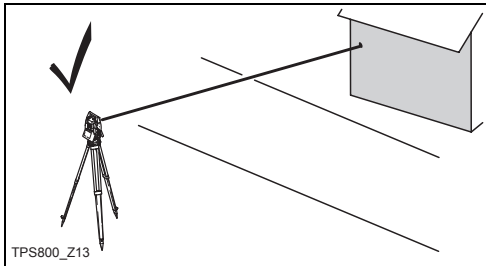

Correct result

## Reflectorless

☞ Be sure that the laser beam is not reflected by anything close to the line of sight (e.g. highly reflective objects).

☞ When a distance measurement is triggered, the EDM measures to the object which is in the beam path at that moment. In case of temporary obstruction (e.g. a passing vehicle, heavy rain, fog or snow) the EDM may measure to the obstruction.

☞ When measuring longer distances, any divergence of the red laser beam from the line of sight might lead to less accurate measurements. This is because the laser beam might not be reflected from the point at which the crosshairs are pointing.

Therefore, it is recommended to verify that the R-laser is well collimated with the telescope line of sight (refer to the chapter "Checking and adjusting").

☞ Do not measure with two instruments to the same target simultaneously.

### Red laser to prisms



Accurate measurements to prisms should be made with the standard program (Infrared mode).

### Red laser to reflector tape

The visible red laser beam can be used to measure to reflective foils, also. To guarantee the accuracy the red laser beam must be perpendicular to the reflector tape and it must be well adjusted (refer to the chapter "Checking and adjusting").



Make sure the additive constant belongs to the selected target (reflector).

## Softkeys

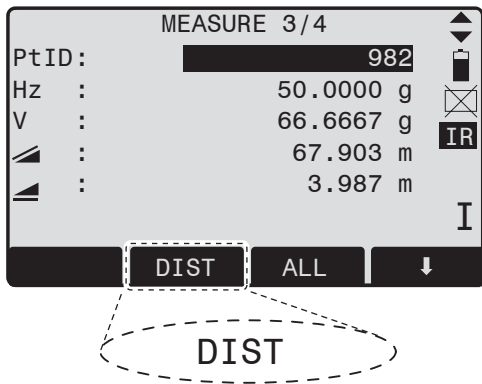

Under softkeys, a selection of commands and functions is listed at the bottom of the screen. They can be activated with the corresponding function keys. The available scope of each function depends on the applications / functions currently active.

### General softkeys:

- [ALL] Starts distance and angle measurements and saves measured values.
- [DIST] Starts distance and angle measurements without saving measured values.
- [REC] Saves displayed values.
- [ENTER] Deletes current value in the display and is ready for the input of a new value.
- [ENH] Opens the coordinate input mode.
- [LIST] Displays the list of available points.
- [FIND] Starts the search for the point entered.
- [EDM] Displays EDM settings.
- [IR/RL] Toggles between infrared and reflectorless measurement modes.
- [PREV] Back to last active dialog.
- [NEXT] Continue to next dialog.
- ← Returns to highest softkey level.
- ↓ To next softkey level.
- [OK] Set displayed message or dialog and quit dialog.
-  Find further information about menu/applicationspecific buttons in the relevant sections.

---

## Symbols

Depending on software version different symbols are displayed indicating a particular operating status.



A double arrow indicates choice fields.



Using the navigation keys the desired parameter can be selected.



Quits a selection with the enter key or the navigation keys.



Indicates that several pages are available which can be selected with [PAGE].

I, II

Indicates telescope position I or II.



Indicates that Hz is set to "left side angle measurement" (anti-clockwise).

### Status symbol "EDM type"



**Infrared EDM** (invisible) for measuring to prisms and reflective targets.



**Reflectorless EDM** (visible) for measuring to all targets.

### Status symbol "Battery capacity"



The battery symbol indicates the level of the remaining battery capacity (75% full shown in the example).

### Status symbol "Compensator"



Compensator is on.



Compensator is off.

### Status symbol "Offset"



Offset is active.

### Status symbol "Character Input"



Numeric Mode



Alphanumeric Mode

## Menu tree

[MENU] > **F1** - **F4** Confirm menu selection.

[PAGE] Scroll to next page.

 Depending on user interface sequence and arrangement of menu items may be different.

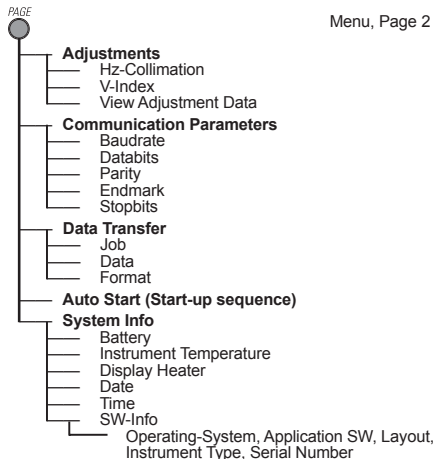
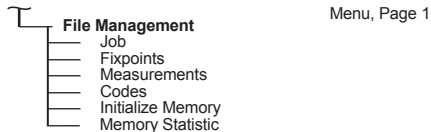
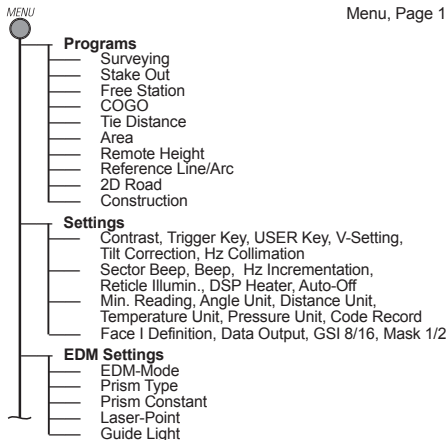

# Measuring Preparation / Setting up

## Unpacking

Remove instrument from transport case and check for completeness:

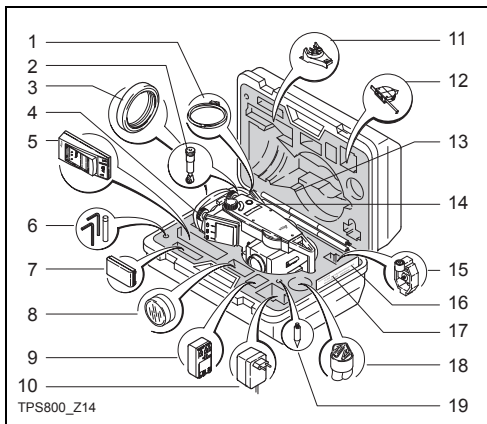

- 1) Data cable (optional)
- 2) Zenith eyepiece or eyepiece for steep angles (optional)
- 3) Counterweight for eyepiece for steep angles (optional)
- 4) Removable tribrach (optional)
- 5) Battery charger and accessories (optional)
- 6) Two Allen keys each, Adjusting pins
- 7) Battery GEB111 (optional)
- 8) Sun filter (optional)
- 9) Battery GEB121 (optional)
- 10) Mains adapter for battery charger (optional)
- 11) Spacing bracket GHT 196 for instrument height meter (optional)
- 12) Instrument height meter GHM 007 (optional)
- 13) Mini prism rod (optional)
- 14) Total Station
- 15) Mini prism + holder (optional)
- 16) Mini target plate (only for TCR instruments)
- 17) User Manual
- 18) Protective cover / Lens hood
- 19) Tip for mini prism (optional)

## Batteries

### Inserting / Replacing Battery

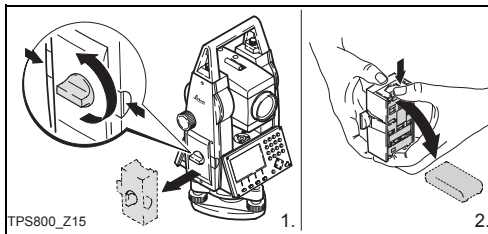

1. Remove battery holder.
2. Remove battery.

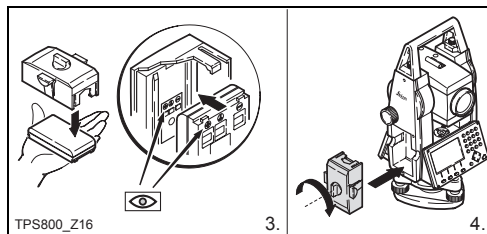

3. Insert battery into battery holder.
4. Insert battery holder into instrument.

 Insert battery correctly (note pole markings on the inside of the battery holder). Check and insert battery holder true to side into the housing.

- To charge the battery refer to chapter "Charging the batteries".
- For the type of battery refer to chapter "Technical data".

 When using the GEB121 battery, remove the spacer for the GEB111 from the battery compartment.

 **Primary use/charging**

- The batteries must be charged prior to using for the first time because it is delivered with an energy content as low as possible.
- For new batteries or batteries that have been stored for a long time (> three months), it is effectual to make 2 - 5 charge/discharge cycles.
- The permissible temperature range for charging is between 0°C to +35°C / +32°F to +95°F. For optimal charging we recommend a low ambient temperature of +10°C to +20°C / +50°F to +68°F.

 **Operation/Discharging**

The batteries can be operated from -20°C to +55°C/-4°F to +131°F.

Low operating temperatures reduce the capacity that can be drawn; very high operating temperatures reduce the service life of the battery.

## Setting up the tripod

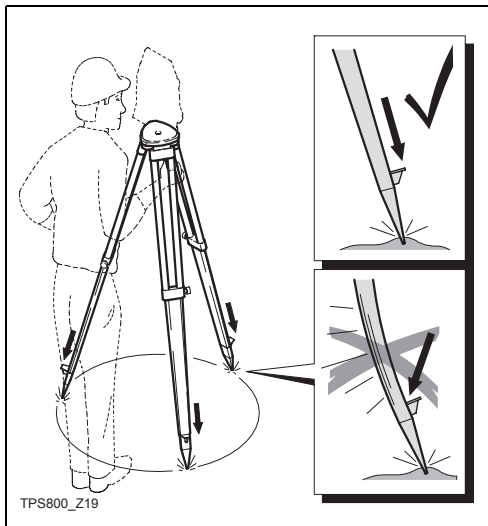

1. Loosen the clamping screws on the tripod legs, pull out to the required length and tighten the clamps.
2. In order to guarantee a firm foothold sufficiently press the tripod legs into the ground. When pressing the legs into the ground note that the force must be applied along the legs.

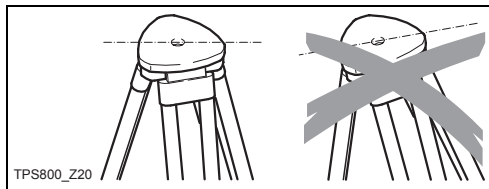

 When setting up the tripod pay attention to a horizontal position of the tripod plate. Slight corrections of inclination can be made with the foot screws of the tribrach. Larger corrections must be done with the tripod legs.

 When using a tribrach with an optical plummet, the laser plummet cannot be used.

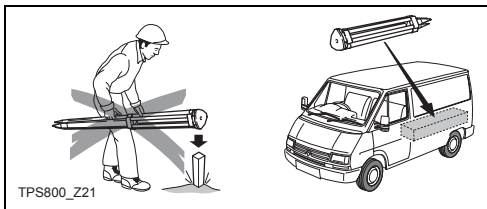

### Careful handling of tripod

- Check all screws and bolts for correct fit.
- During transport always use the cover supplied.
- Use the tripod only for surveying tasks.

## Centring with laser plummet, coarse level-up

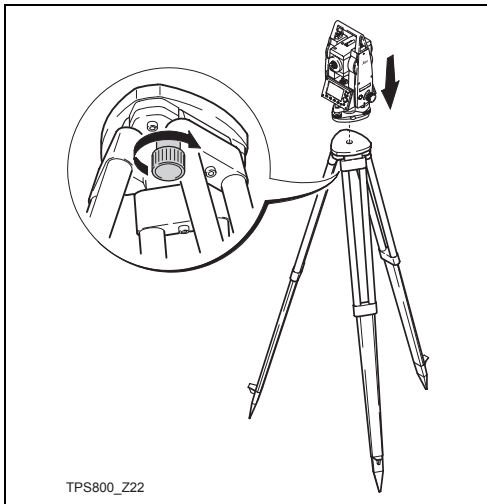

1. Place the instrument onto the tripod head. Tighten central fixing screw of tripod slightly.
2. Turn footscrews of tribrach into its centre position.
3. Switch on the laser plummet with [FNC] > [Level/Plummet]. The electronic bubble is displayed.
4. Position tripod legs so that the laser beam is aimed to the ground point.
5. Firmly press in tripod legs.
6. Turn the footscrews of the tribrach to centre the laser beam exactly over the ground point.
7. Move the tripod legs to centre the circular level. The instrument is now roughly levelled-up.

## ***Fine tuning in the horizontal with the electronic bubble***

1. Switch on the electronic bubble with [FNC] > [Level/Plummet]. In case of insufficient levelling-up an inclined level symbol appears.
2. Center the electronic bubble by turning the foot screws.

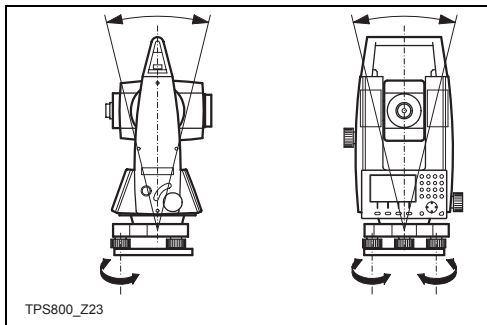

When the electrical bubble is centered, the instrument is leveled.

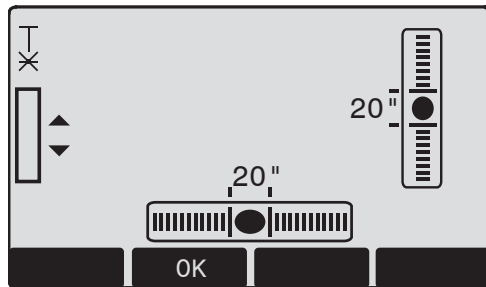

3. Check centring with the laser plummet and re-centre if necessary.
4. Switch off the electronic bubble and the laser plummet by pressing [OK] .

## Laser intensity

### Changing the laser intensity

External influences and the surface conditions may require the adjustment of the intensity of the laser. The laser can be adjusted in 25% steps as required.

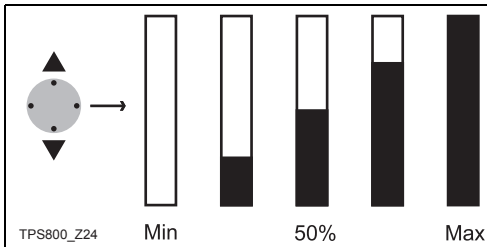

## Hints for positioning

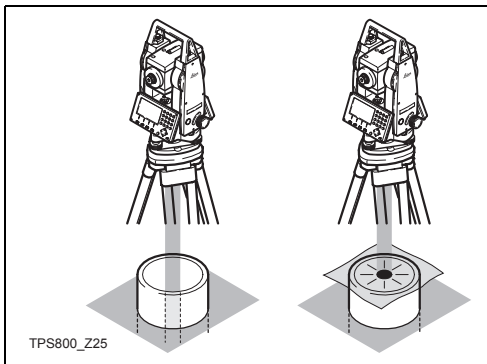

### Positioning over pipes or depressions

Under some circumstances the laser dot is not visible (e.g. over pipes). In this case, the laser dot can be made visible by using a transparent plate so the the laser dot can be easily aligned to the centre of the pipe.

---

## Input mode

Due to the alphanumeric keypad you can enter characters directly.

- **Numeric fields:**

Can only contain numerical values.

By pressing a button of the numeric keypad the number will be displayed.

- **Alphanumeric fields:**

Can contain numbers and letters.

By pressing a button of the alphanumeric keypad the input opens. By pressing several times you can toggle through the characters.

For example: 1->S->T->U->1->S....

## Edit characters



1. Place cursor on character to be edited.

2. Input the new character.



3. Confirm input.

## Erasing characters



1. Place cursor on character to be deleted.



2. Pressing the navigation key deletes the relevant character.



3. Confirm input.

[ESC]

Deletes the change and restores the previous value.

## Inserting characters

If a character was skipped (e.g. -15 instead of -125) you can insert it later.



1. Place cursor on "1".



2. Inserts an empty character on the right of "1".

3. Input the new characters.



4. Confirm input.

## Character set

Entry mode contains the following characters for numeric and alphanumeric input.

Numerical		Alphanumeric	
" + "	(ASCII 43)	" " "	(ASCII 32) [space]
" - "	(ASCII 45)	" ! "	(ASCII 33)
" . "	(ASCII 46)	" # "	(ASCII 35)
" 0 - 9 "	(ASCII 48 - 57)	" \$ "	(ASCII 36)
		" % "	(ASCII 37)
		" & "	(ASCII 38)
		" ( "	(ASCII 40)
		" ) "	(ASCII 41)
		" * "	(ASCII 42)
		" + "	(ASCII 43)
		" , "	(ASCII 44)
		" - "	(ASCII 45)
		" . "	(ASCII 46)
		" / "	(ASCII 47)
		" : "	(ASCII 58)
		" < "	(ASCII 60)
		" = "	(ASCII 61)
		" > "	(ASCII 62)
		" ? "	(ASCII 63)
		" @ "	(ASCII 64)
		" A - Z "	(ASCII 65 .. 90)
		" _ "	(ASCII 95)
		" ` "	[Underscore] (ASCII 96)

The character entry "\*" can be used in data fields where point numbers or codes can be searched for.

## Signs

+/- In the alphanumeric character set "+" and "-" are treated as normal alphanumeric characters with no mathematical function.

## Additional characters

\* Place holder during Wildcard point search (see chapter "Wildcard search").



"+" / "-" appears only in the front position of an input.



In the edit mode the position of the decimal place cannot be changed. The decimal place is skipped.

## Pointsearch

Pointsearch is a global function used by applications to e.g. find internally saved measured or fixed points.

It is possible for the user to limit the point search to a particular job or to search the whole storage.

The search procedure always finds fixed points before measured points that fulfill the same search criteria. If several points meet the search criteria, then the points are listed according to their age. The instrument finds the most current (youngest ) fixed point first.

### Direct search

By entering an actual point number (e.g. "P13") all points with the corresponding point number are found.

P13	FIXPT
P13	MEAS
P13	MEAS

VIEW    JOB    OK    ↓

- [VIEW]      Displays the coordinates of the selected point.
- [ENH]      For manual input of coordinates.
- [OK]        Confirm selected point.
- [JOB]        To select a different job.

POINT SEARCH

Job :                    ALL JOBS ◀▶

PtID:                    P13

## Wildcard search

The Wildcard search is indicated by a "\*". The asterisk is a place holder for any following sequence of characters.

Wildcards are always used if the point number is not fully known, or if a batch of points is to be searched for.

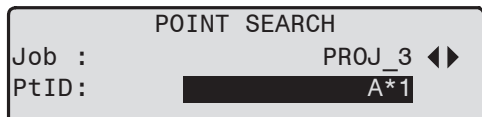

POINT SEARCH

Job : PROJ\_3 ◀▶

PtID: ██████████ A\*1



Starts point search.

### Examples:

- \* All points of any length are found.
- A All points with exactly the point number "A" are found.
- A\* All points of any length starting with "A" are found (e.g.: A9, A15, ABCD).

\*1 All points of any length with a "1" as the second character are found (e.g.: A1, B12, A1C).

A\*1 All points of any length with an "A" as the first character and a "1" as the third character are found.

(e.g.: AB1, AA100, AS15).

## Measuring

After switching on and setting up correctly, the Total Station is immediately ready for measuring.

In the measurement display it is possible to call up fixed keys and function keys, as well as trigger keys and their functions.

 All shown displays are examples. It is possible that local software versions are different to the basic version.

Example of a possible measuring display:

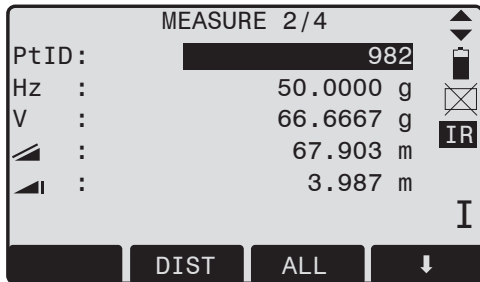

**F1** - **F4** Calling up the assigned function.

## **FNC Key**

Under [FNC] several functions can be called up. Their applications are described below.

 Functions can also be started directly from the different applications.

 Each function from the FNC menu can be assigned to the [USER]-key (see chapter "Settings").

---

### **Light On /Off**

Switches display light on / off.

---

### **Level/Plummet**

This function enables the electronic bubble and the range of intensity settings of the laser plummet.

---

### **IR/ RL Toggle**

Change between the two EDM types IR (Infrared) and RL (Reflectorless). New setting is displayed for about one second.

IR: Infrared: Distance measurements with prisms.  
RL: Visible laser: Distance measurements without prisms up to 170m; with prisms from 1 km.  
Find more information in chapter "EDM Settings".

---

### **Laser Pointer**

Switches on or off the visible laser beam for illuminating the target point. The new settings are displayed for about one second and then saved.

---

### **Free-Coding**

Select code from the codelist or enter a new code.

---

### **Units**

Displays the current distance and angle unit and gives the possibility to change these.

---

## Delete Last Record

This function deletes the last recorded data block. This can be either a measurement block or a code block.

 Deleting the last record is **not reversible** !

 Only records can be deleted which were recorded in "Surveying" or in "Measuring".

---

## Check Tie

Calculation and display of the slope and horizontal distance, height difference, azimuth, grade, and coordinate differences between the last two measured points. Valid distance measurements are required for the calculation.

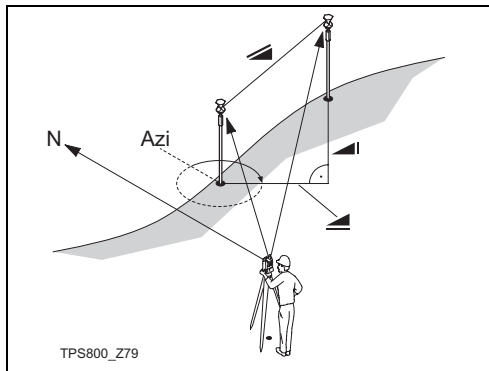

### Important Messages

Less than two valid measurements!

### Meaning

The values cannot be calculated as there exist less than 2 valid measurements.

## Tracking

Switches on or off the tracking measurement mode. The new setting is displayed for approx. one second and then set. The function can only be activated from within the same EDM type and prism type.

The following options are available:

EDM Type	Tracking measurement mode Off $\Leftrightarrow$ On
IR	IR-Fine $\Leftrightarrow$ IR_Track / IR-Fast $\Leftrightarrow$ IR-Track
RL	RL-Short $\Leftrightarrow$ RL-Track

The last active measurement mode remains set when the instrument is switched off.

## Target Offset

If it is not possible to set up the reflector directly, or it is not possible to aim the target point directly, the offset values (length, cross and/or height offset) can be entered. The values for the angle and distances are calculated directly for the target point.

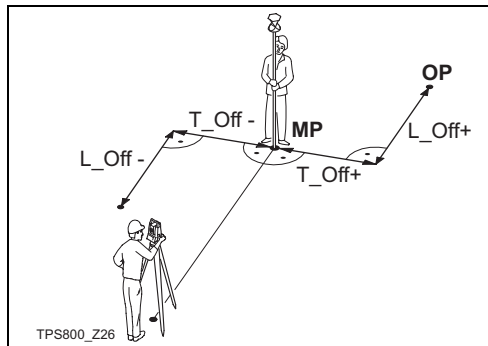

MP: Measurement point  
OP: Offset point

T\_Off: Length offset

L\_Off: Cross offset

H\_Offset +: Offset point is higher than measurement

TARGET OFFSET	
T_Offset:	0.600 m
L_Offset:	0.800 m
H_Offset:	0.500 m
Mode :	PERMANENT ◀▶
INPUT	RESET
SET	

#### Procedure:

1. Enter the offset values (length, cross and/or height) as per the sketch.
2. Define the period for which the offset is to apply.
3. [RESET]: Sets eccentricity to zero.
4. [SET]: calculates the corrected values and jumps to the application from which the offset function was started. The corrected angle and

distances are displayed as soon as a valid distance measurement has been triggered or exists.

#### The period of applicability can be set as follows:

Reset after REC	The offset values are reset to 0 after the point is saved.
Permanent	The offset values are applied to all further measurements.

 The offset values are always reset to 0 when the application is quit.

---

## Main Settings

Enables you to change the most important settings.

## Height Transfer

Example:

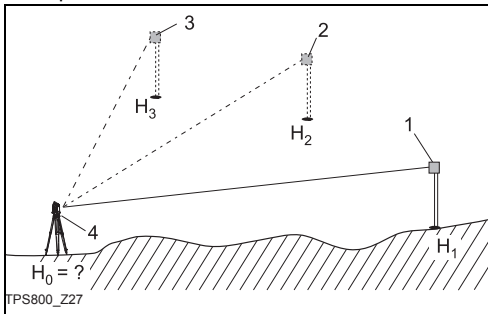

- 1) Reflector 1
- 2) Reflector 2
- 3) Reflector 3
- 4) Instrument

This function determines the height of the instrument from measurements to a maximum of 5 target points, with known heights, in two faces. With measurements to several targets, the improvement is indicated in the "delta" value.

### Procedure:

1. Select known point and input reflector height.
2. After triggering the measurement with [ALL], the calculated height  $H_0$  is displayed.
  - [AddPt] Add another height of a known point.
  - [FACE] Measure to the same target in second face.
3. [SET] Save the changes and set the station.

## Hidden Point

Example:

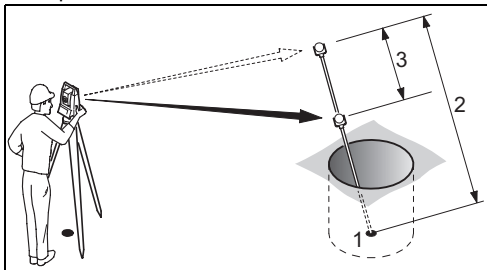

- 1 E, N, H of Hidden Point
- 2 Rod Length
- 3 Distance R1-R2

The program allows measurements to a point that is not directly visible, using a special hidden-point rod.

### Procedure:

1. Measure to first prism (P1).  
[All] Starts measurement and proceeds to step 2.  
[ROD] Allows you to define the rod and the EDM-Settings.

### Rod Length

Total length of hidden-point rod.

### Dist. R1-R2

Spacing between the centers of reflector R1 and prism R2.

### Meas. Tol

Limit for the difference between the given and measured spacing of the reflectors. If the tolerance value is exceeded, the program will issue a warning.

### EDM-Mode

Changes the EDM-Mode.

### Prism type

Changes the prism type.

### Prism Const

Displays the prism constant.

2. [All] Starts measurement and proceeds to the Result dialog.
3. Result is displayed.

HIDDEN POINT RESULT			
PtID	:		12
Desc.	:		GR
East	:	110.871	m
North	:	99.991	m
Heigth	:	102.884	m

FINISH      NEW

[NEW] Returns to step 1.

[FINISH] Returns to calling application.

# Programs

## Application pre-settings

These are programs that precede the application programs and are used to set up and organize data collection. They are displayed after selecting an application. The user can select the start programs individually.

SETTING OUT	
[ ● ]	F1 Set Job
[ ● ]	F2 Set Station
[ ]	F3 Set Orientation
	F4 Start

F1      F2      F3      F4

[ ● ] Settings made.

[ ] Settings not made.

 Find further information about individual start-up programs on the subsequent pages !

## Setting job

All data is saved in JOBS, like directories. Jobs contain measurement data of different types (e.g. measurements, codes, fixed points, stations,...) and are individually manageable and can be readout, edited or deleted separately.

[NEW]      Creating a new job.

[SET]      Setting the job and back to start-up programs.

 All subsequent recorded data is stored in this job/directory.

 If no job was defined and an application was started or if in "Meas & Rec" [ALL] or [REC] was triggered, then the system automatically creates a new job and names it "DEFAULT".

## Setting Station

Each coordinate computation relates to the currently set station.

At least plan coordinates (E, N) are required for the station. The station height can be entered if required. The coordinates can be entered either manually or read from the internal memory.

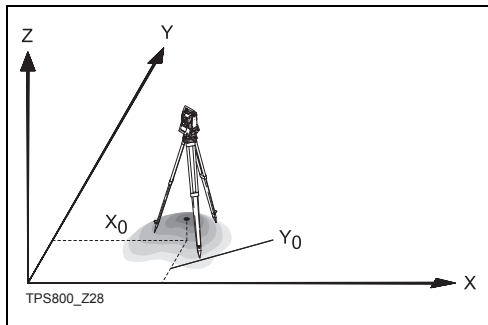

## Known Point

1. Select a PtID stored in internal memory.
2. Input instrument height.  
[OK] Sets the station.

## Set manually

1. [ENH] Calls up manual point input dialogue.
2. Input PtID and coordinates.
3. [SAVE] Saves station coordinates.  
Continues to the input of the instrument height.
4. [OK] Sets the station.

 If no station was set and no application started and if in "Meas & Rec" [ALL] or [REC] was activated, then the last station is set as the current station.

## Orientation

With the orientation, Hz-direction can be input manually or points with known coordinates can be set.

### Method 1: Manual input

1. **F1** To input a random Hz-orientation.
2. Input of Hz-direction, reflector height and PtID.
3. **[ALL]** Triggers measurement and sets orientation.  
**[REC]** Records Hz-direction and sets orientation.

### Method 2: with coordinates

To determine the orientation, a target with known coordinates can also be used.



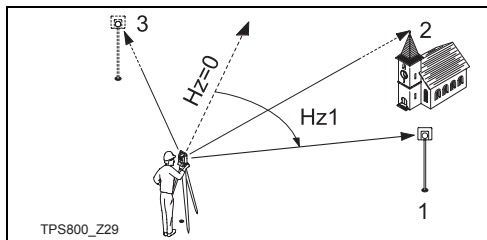

1. **F2** As orientation with coordinates.
2. Input of the orientation point number and to determine the point found.
3. To input and confirm the reflector height.

For determining the orientation a maximum of 5 target points with known coordinates can be used.



- 1) 1. Target point
- 2) 2. Target point
- 3) 3. Target point

Orientation coordinates can be either obtained from the internal memory or entered manually.

SIGHT TARGET POINT		3/I II
PtID :	201	
hr :	1.300 m	
BsBrg :	236° 56' 14"	
▲ Hz :	51° 12' 23"	
▲  :	0.569 m	

ALL    DIST    REC    EDM

After each measurement you are asked whether to proceed or not. Answering with yes brings you back to the Measurement dialog, to take an additional measurement. Answering with no brings you to the Result dialog

- 1/I    Status indication; shows that first point was measured in telescope position I.
- 1/I II    First point measured in telescope pos. I and II.

- ▲ Hz: After the first measurement the finding of other target points (or the same point when changing the telescope position) is easier by setting the indicated angle difference near to 0°00'00" by turning the instrument.
- ▲ : Difference between horizontal distance to target point computed from coordinates and the measured distance.

### Display of computed orientation

ORIENTATION RESULT	
NoPts. :	2
Station :	200
HzCor :	123° 00' 23"
StDev :	± 0° 00' 08"

PREV    RESID    OK

[OK]    Set computed Hz-orientation.

If more than one target point is measured then the orientation is computed using the "least squares method".

### Displaying residuals

[RESID] Display of residuals.

RESIDUALS		1 / 3
BsPt :	ABC1	◀▶
▲Hz :	-0°00'23"	
▲▴ :	-0.045 m	
▲H :	0.075 m	
HzCor:	123°00'23"	

PREV

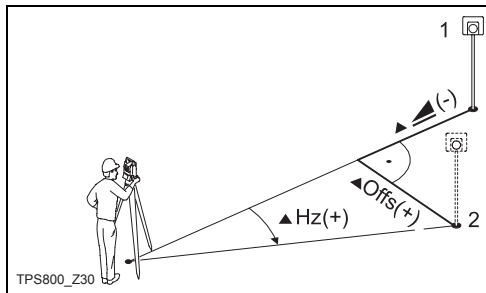

- 1) Actual
- 2) Design

▲H: Height correction  
 ▲▴: correction of the horizontal distance  
 ▲Hz: Correction of Hz-angle.

### ***Useful information***

- If the orientation is only measured in telescope position II the Hz-orientation is based on telescope position II. If measured only in telescope position I or mixed the Hz-orientation is based on telescope position I.
- The prism height may not be changed during measurements in the first and second telescope position.
- If a target point is measured several times in the same telescope position the last valid measurement is used for the computation.

 If no orientation was set and an application was started resp. if in "Meas & Rec" [ALL] or [REC] was triggered, then the current Hz-direction and V-angle are set as orientation.

---

## **Applications**

### **Introduction**

Applications are predefined programs, that cover a wide spectrum of surveying duties and facilitate daily work in the field.

The following applications are available:

- Surveying
- Stake Out
- Tie Distance
- Area (plan)
- Free Station
- Reference Line/Arc
- Remote Height
- Construction
- Cogo (optional)
- 2D-Road (optional)

[MENU]

1. Press the [MENU] fixed key.

**F1**

2. Selecting the "Program" option.

**F1** - **F4**

3. Calling up applications and activating start programs.

[PAGE] Scroll to next page.

## Surveying

With the program Surveying the measurement of an unlimited number of points is supported. It is comparable to "Meas & Rec", but includes stationing, orientation and coding.

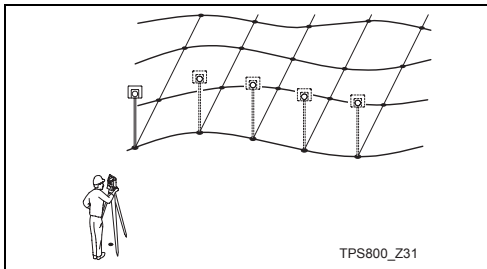

### Procedure:

1. Input PtID, codes and the reflector height if desired.
2. [ALL] Triggers and records measurements.  
[IndivPt] Switches between individual and current point number.

### Three coding methods are available:

1. Simple coding:  
Input a code into the relevant box. The code is stored along with the corresponding measurement.
2. Expanded coding:  
Press the [CODE] softkey. The code that was input is searched for within the code list and it is possible to add attributes to the code.
3. Quick coding:  
Press the [Q-Code] softkey and enter the shortcut to the code. The code is selected and the measurement starts.

## Stake out

This program calculates the required elements to stakeout points from coordinates or manually entered angles, horizontal distances and heights. Stake out differences can be displayed continuously.

### Stake out coordinates from memory

#### Procedure:

- ◀▶ Select the point.
- [DIST] Starts measurement and calculation of the stake-out elements.
- [REC] Saves the displayed values.
- [B&D] Input direction and Hz-distance of stake out point.
- [MANUAL] Enables simplified input of a point without PtID and without the possibility of storing the data of the point.

## Polar Stake out

Normal indication of polar stake out offsets.

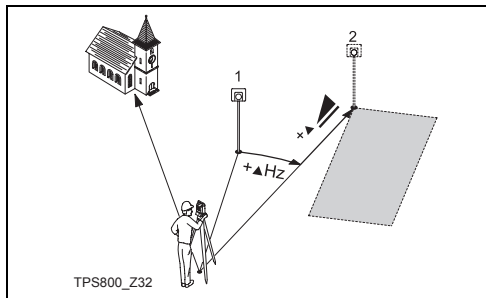

- 1) Actual
  - 2) Point to be stake out
- ▲Hz: Angle offset: positive if point to be set-out is to the right of the actual direction.
  - ▲▲: Longitudinal offset: positive if point to be stake out is further away.
  - ▲▲|: Height offset: positive if point to be stake out is higher than measured point.

## Orthogonal Stake out

The position offset between measured point and stake out point is indicated in a longitudinal and transversal element.

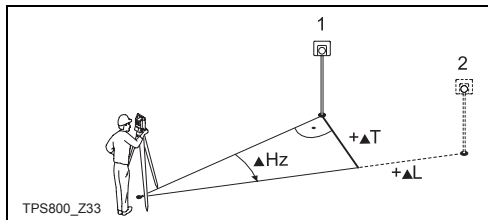

- 1) Actual
- 2) Point to be stake out

$\Delta L$ : Longitudinal offset: positive if nominal point further away.  
 $\Delta T$ : Transversal offset, perpendicular to line-of-sight: positive if nominal point is to the right of measured point.

## Cartesian Stake out

Stake out is based on a coordinate system and the offset is divided into a north and east element.

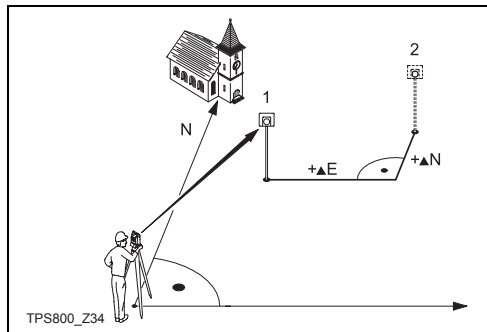

- 1) Actual
- 2) Point to be stake out

$\Delta E$  Easting offset between stake out and actual point.  
 $\Delta N$  Northing offset between stake out and actual point.

## Free Station

The application "Free Station" is used to determine the instrument position from measurements to a minimum of two known points and a maximum of five known points.

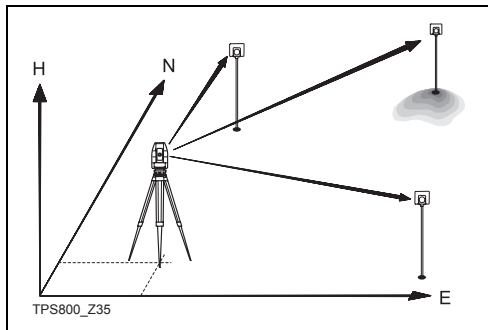

The following measurements sequences to target points are possible:

1. Hz- and V-angles only (resection)
2. Distance and Hz- and V-angle (3 point resection)
3. Hz- and V-angles to some point(s) and Hz- and V-angle plus distance to other point(s).

The final computed results are Easting, Northing and Height of the present instrument station, including the instruments Hz-circle orientation. Standard deviations and residuals for accuracy assessments are provided.

## Measuring facilities

Single face I or II or dual face I + II measurements are always possible. No specific point sequence or specific face sequences are required.

Gross errors checks are made for dual face measurements to ensure the same point(s) are sighted with the other face.



If a target point is measured several times in the same telescope position the **last valid measurement** is used for computation.

### Measurement restrictions:

- **2 face measurements**

When measuring the same target in both faces, the reflector height may not be altered when changing the telescope position.

- **Target points with 0.000 height**

Target points with 0.000 height are discarded for height processing. If target points have a valid height of 0.000 m, use 0.001 m to enable it for height processing.

## Computation procedure

The measuring procedure automatically determines the method of evaluation, e.g. resection, 3 point resection, etc.

If more than the minimum required measurements are performed, the processing routine uses a least squares adjustment to determine the plan position and averages orientation and heights.

1. The original averaged face I and face II measurements enter the computation process.
2. All measurements are treated with the same accuracy, whether these are measured in single or dual face.
3. Easting and northing is determined by the method of least squares, including standard deviation and improvements for Hz-direction and horizontal distances.
4. The final height (H) is computed from averaged height differences based on the original measurements.
5. The Hz-circle orientation is computed with the original averaged face I and face II measurements and the final computed plan position.

## Procedure:

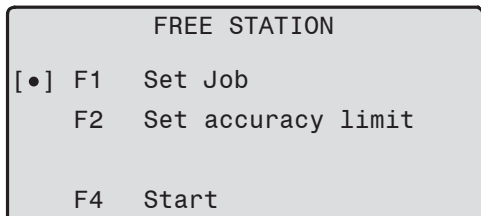

**F2** Enables you to define an accuracy limit.

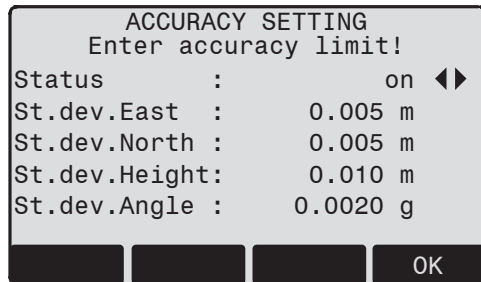

Here you can enter a limit for the standard deviation values. If your computed deviation exceeds the limit a warning dialog appears, where you can decide whether to proceed or not.

1. Input of the name of the station and the height of the instrument.
2. Input of the target PtID and the reflector height.

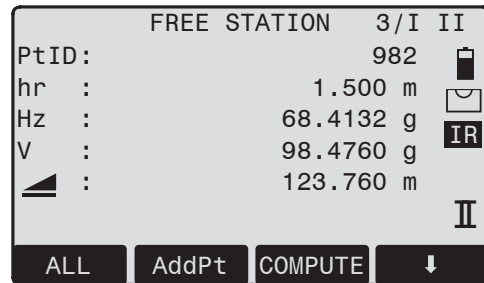

- [ALL] Triggers angle and distance measurement (3 point resection).
- [REC] Saves Hz-direction and V-angle (resection).

[AddPt]	Input another backsight point.
[COMPUTE]	Calculates and displays the station coordinates, if at least 2 points and a distance were measured.
3/I	Indicates that the third point in telescope position I was measured.
3/I II	Indicates that the third point in telescope positions I and II.

## Results

### Displays calculated station coordinates:

FREE STATION RESULT	
Station :	Stp1
hi :	1.560 m
E0 :	102.338 m
NO :	406.426 m
H0 :	99.350 m

AddPt RESID StdDev SET

[AddPt]	Switches to measurement display, to measure additional points.
[RESID]	Displays residuals.
[STDEV]	Displays standard deviation.
[SET]	Sets the displayed coordinates and instrument height as new station.

 If the instrument height was set to 0.000 in the setup screen, then the station height refers to height of trunnion axis.

### Displays standard deviations:

FREE STATION STD. DEVIATIONS	
POINTS:	3
S.Dev E0:	0.028 m
S.Dev N0:	0.012 m
S.Dev H0:	0.030 m
S.Dev Ang:	0.0020 g

BACK

S.Dev E0, N0, H0 Standard deviation of the station coordinates

S.Dev Ang Standard deviation of the orientation

**This dialog shows the computed residuals:**  
Residual = Calculated value - Measured value

FREE STATION RESIDUALS 1/3	
PtID :	Target 1 ◀▶
▲ Hz :	0.0020 g
▲  :	0.030 m
▲ H :	0.028 m

BACK



With the function keys, scroll between the residuals of the individual backsight points.

## Warnings / Messages

Important messages	Meaning
Selected point has no valid data !	This message occurs if the selected target point has no easting or northing coordinate.
Max 5 points supported !	If 5 points have already been measured and another point is selected. The system supports a maximum of 5 points.
Invalid data - no position computed !	The measurements may not allow final station coordinates (Easting, Northings) to be computed.
Invalid data - no height computed !	Either the target height are invalid or insufficient measurements are available to compute a final station height.
Insufficient space in job !	The present selected job is full and does not allow further storage.
Hz (I - II) > 0.9 deg, measure point again !	This error occurs if a point was measured in one face and the measurement in the other face differs by more than $180^\circ \pm 0.9^\circ$ for the horizontal angle.
V (I - II) > 0.9 deg, measure point again !	This error occurs if a point was measured in one face and the measurement in the other face differs by more than $360^\circ - V \pm 0.9^\circ$ for the vertical angle.
More points or distance required !	There is insufficient data measured to be able to compute a position. Either there are not enough points used or not enough distances measured.

## Reference Line/Arc

This program facilitates the easy stake out or checking of lines for buildings, sections of road, simple excavations, etc.

### Reference Line

A reference line can be defined by referencing a known base line. The reference line can be offset either longitudinally or in parallel to the base line, or be rotated around the first base point as required.

### Definition of the Base line

The base line is fixed by two base points that can be defined in three ways:

- Measured points
- Enter co-ordinates using keypad
- Select point from memory.

### Definition of the base points

#### Procedure:

#### 1. Measuring base points:

Input PtID and measure base points with [ALL] or [DIST] / [REC].

#### 2. Base points with coordinates:

- [FIND] Starts to search for the PtID entered.
- [ENH] Manually input coordinates.
- [LIST] Displays the list of available points.

Analogue procedure for the second base point.

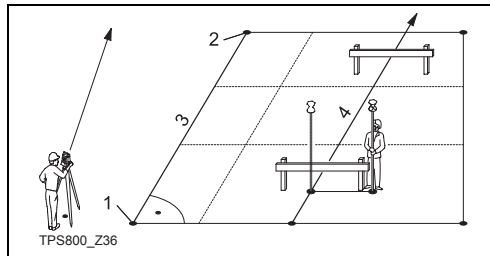

- 1) 1st base point
- 2) 2nd base point
- 3) Base line
- 4) Reference line

## Base line

The base line can be offset longitudinally and parallel, or rotated. This new line is called the reference line. All measured data refers to the reference line.

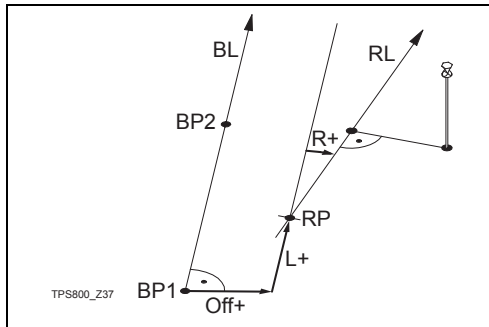

BP: Base point  
BL: Base line  
RP: Reference point  
RL: Reference line

Off: Length offset  
L: Line offset  
Rot: Rotation parameter

### Input of the parameters:



Use the navigation keys to select the shifting and rotation parameters of the reference line.

BASELINE SHIFTS	
Point 1 :	1000
Point 2 :	1001
Offset :	1.000 m
Line :	0.500 m
H-Offset :	0.900 m
Rotate :	25.0000 g

NewBL | SHIFT=0 | L&O | RefLine

### The following entries are possible:

Offset+: Parallel offset of the reference line to the right, referred to the direction of the base line (1-2).

- Line+: Longitudinal offset of the start point (=reference point) of the reference line in the direction of base point 2.
- Rotate+: Rotation of the reference line clockwise around the reference point.
- H-Offset+: Height offset; the reference line is higher than the first base point.

Meaning of the softkeys:

- [NewBL] Return to the definition of a new base line.
- [STAKE] Opens the "Orthogonal Stake out" application.
- [MEASURE] Opens the "Line&Offset" application.
- [SHIFT=0] Sets offset / rotation to zero.

## Reference Line

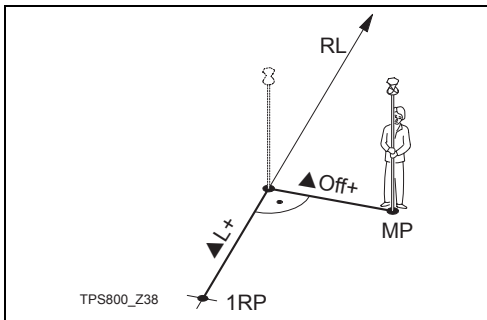

- 1RP: 1st reference point  
 MP: Measured point  
 RL: Reference line  
 ▲L: Longitudinal offset  
 ▲Off: Cross offset

The [L&O] function calculates from measurements or coordinates longitudinal, cross and height differences of the target point relative to the reference line.

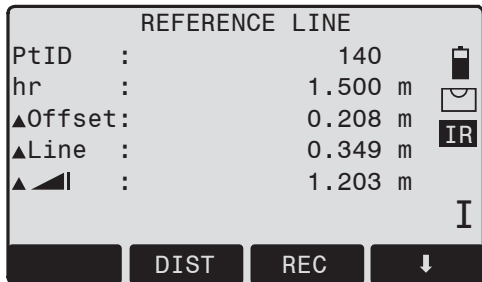

The height of the first reference point is always used as the reference height for the calculation of height differences (▲Line).

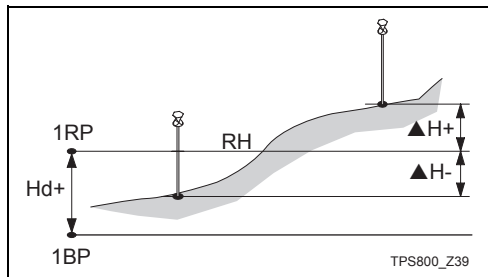

1RP: 1st reference point



1BP: 1st base point

RH: Reference height

Hd: Height difference between reference and base point

▲H: Height difference from reference height

## Orthogonal Stake out

You can enter longitudinal, transverse and height offsets for the target points to be set-out relative to the reference line. The program calculates the difference between a measured point and the calculated point. The program displays the orthogonal (pLine, pOffset, p ) and the polar (pHz, p , p ) differences.

Procedure:

1. Input the orthogonal stake out elements or call up of a point from internal memory.
2. [SET] Confirm entry and start calculation.

## Example "orthogonal methods"

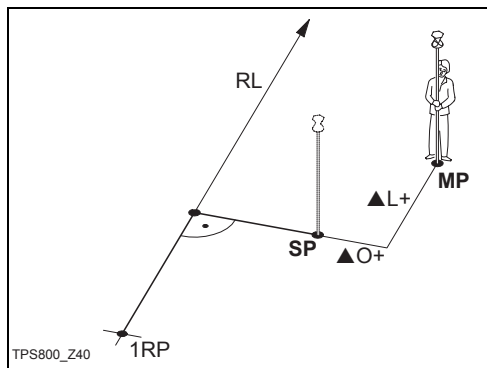

1RP: 1st reference point

MP: Measured point





SP: Stake out point

RL: Reference line

▲L: Longitudinal offset

▲Off: Cross offset

## Display in measure mode:

ORTHOGONAL STAKEOUT 1/2		
PtID :	15	
hr :	1.500 m	
▲Hz :	→ +0.200 g	
▲  :	↓ 2.368 m	
▲    :	↓ 0.260 m	

I

DIST REC ↓

▲Offset :	→ 2.040 m	
▲Line :	↓ 1.203 m	
▲    :	↓ 0.260 m	

The signs for the distance and angle differences are exactly the same as for the "Stake out" application. These are correction values (required minus actual).

+▲Hz

Turn telescope clockwise to the stake out point.

+▲ 

The stake out point is further away than the point measured.

+▲  |

The stake out point is higher than the measured point.

## Reference Arc

This application allows the user to define a Reference Arc and then measure or stake out with respect to the arc.

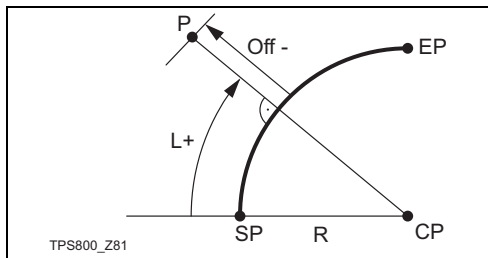

- SP: Start point of arc  
EP: End point of arc  
CP: Centre point of circle  
P: Point to stake  
R: Radius of circle  
L: Distance from start of arc, following curve  
Off: Perpendicular distance from arc



- All arcs are defined in clockwise direction.
- All calculations are made in two dimensions.

### Procedure:

#### 1. Define the arc

When starting the application you were asked how to define the arc. You can define the arc by:

- Center Point & Start Point
- Start Point, End Point, Radius

Depending from type you have chosen, you have to measure/select/enter the values to proceed to step 2.

#### 2. Decide to Measure or to Stake Out

[MEASURE] Starts the subapplication to measure Line & Offset (See issue 3).

[STAKE] Starts the subapplication to stake out (See issue 4).

#### 3. "Line & Offset" subapplication

Here you can measure or select points from memory and you will see Line and Offset referring to the arc.

#### 4. "Stake Out" subapplication

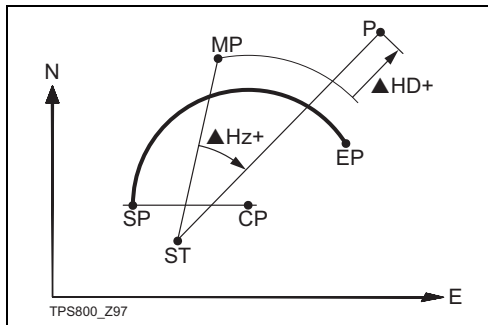

- SP: Start point of arc  
EP: End point of arc  
CP: Centre point of circle  
P: Point to stake out  
ST: Station  
MP: Measured point  
▲Hz: Difference in horizontal angle  
▲HD: Difference in distance measurement

It is not possible to stake out a negative Line.  
The application support four ways to stake out.

##### a) Stake Out Point

This allows to stake out a point by entering a line and an offset value.

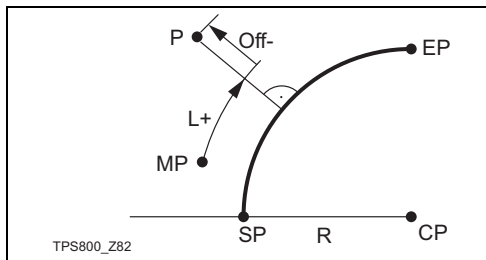

- SP: Start point of arc  
EP: End point of arc  
CP: Centre point of circle  
P: Point to stake out

MP: Measured point  
R: Radius of circle  
L: Line  
Off: Perpendicular distance from arc

### b) Stake Out Arc

This allows to stake out a series of equidistant points along the arc.

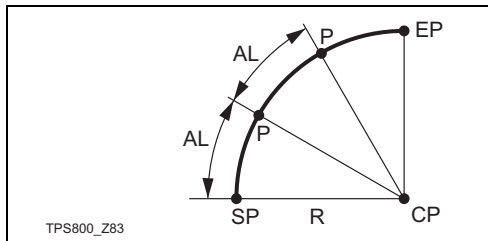

SP: Start point of arc  
EP: End point of arc  
CP: Centre point of circle  
P: Point(s) to stake out  
AL: Arc length

STAKE OUT ARC	
PtID :	147
Misclosure :	EQUAL ◀▶
Arc Length :	7.853 m
Line :	15.711 m
Offset :	0.000 m
RESET   PT-   PT+   OK	

### Display content:

Misclosure: If the entered arc length is not an integer of the whole arc, there will be a misclosure.

You have three options to distribute the misclosure:

- I) Start arc: All of the misclosure will be added to the first arc-section.
- II) No distribution: All of the misclosure will be added to the last arc-section.

- III) Equal: The misclosure will be equally distributed between all sections.
- Arc Length: Enter the length of the arc-segment you want to stake out.
- Line: Shows the line-value of the stake out point. This is calculated by the arc length and the selected misclosure distribution.
- Offset: Here you can enter the offset value.  
 [RESET] Sets the values to 0.  
 [PT +][PT -] Toggles through the calculated stake out points.
- [OK] Proceeds to Stake Out Measure dialog.

### c) Stake Out Chord

This allows to stake out a series of equidistant chords along the arc. The screen contents and the buttons shown, are the same as described in "Stake Out Arc" section.

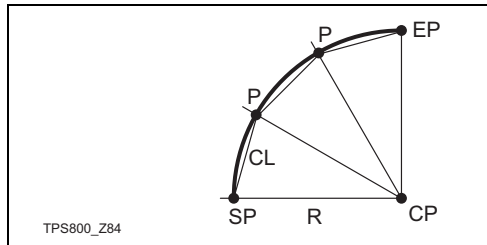

CL: Chord length

#### d) Stake Out Angle

This allows to stake out a series of points along the arc defined by the angle subtended at the center of the angle. The screen contents and the buttons shown, are the same as described in "Stake Out Arc" section.

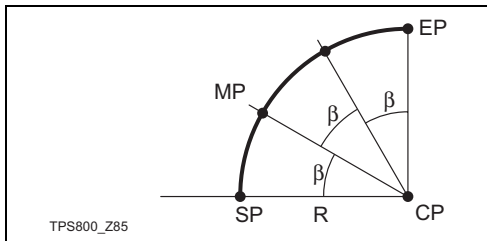

$\beta$ : Angle



## 2. Determine second target point.

Proceed as with first target point.

## 3. Result is displayed.

Brg Azimuth between point1 and point2.



Slope distance between point1 and point2.



Horizontal distance between point1 and point2.



Height difference between point1 and point2.

Grade Grade [%] between point1 and point2.

## Softkeys - polygonal method:

[NewPt 1] An additional missing line is computed. Program starts again (at point 1).

[NewPt 2] Point 2 is set as starting point of a new missing line. New point (Pt 2) must be measured.

[RADIAL] Switches to radial method.

## Softkeys - radial method:

[NewPt 1] Determine new central point.

[NewPt 2] Determine new radial point.

[POLY] Switch to polygonal method.

## Area (plan)

The application areas (plane) computes online areas from an unlimited number of points connected by straights. The points can be measured, selected from memory or input with the keyboard.

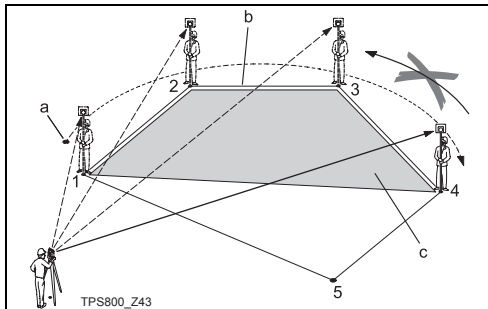

- Start
- Polygonal length, from starting point to the actual measured point.
- Actual area, always closed to the starting point (1).

### Procedure:

- Determine the first area point  
[ALL] Starts the measurement to the point.  
[FIND] Searches internal memory for point entered.  
[XYZ] For manual input of the coordinates.
- Determine additional area points  
Proceed as with first area point.  
[RESULT] Displays additional results (Circumference).

 The area is calculated and displayed once three points have been measured or selected.

## Remote Height

Points directly above the base prism can be determined without a prism at the target point.

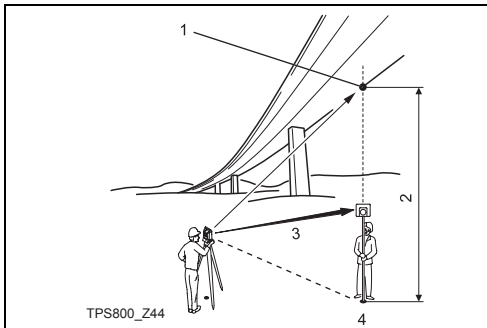

- 1) Remote point
- 2) Height diff.
- 3) Slope distance
- 4) Base point

## Procedure:

### 1. Input PtID and reflector height

- [ALL] Starts measurement to base point and continues to 2.
- [hr?] Starts the program that determines an unknown reflector height.
- 1.1 [ALL] Starts measurement to base point.
- 1.2 Aim at top of reflector and confirm with [Set\_V].

### 2. Aim at inaccessible height point

- [SAVE] Saves the measured data.
- [BasePt] Input and measurement of a new base point.

## Construction

This application allows to define a construction site by combining set-up of the instrument along a construction line, measuring and stake out points in relation to the line.

**After selecting the application you have two options:**

- Defining a new construction site  
or
- Continue with previous site (skips set-up)

**Procedure:**

**Defining new site:**

- Measure line Start point [ALL], [DIST]+[REC]
- Measure second line point [ALL], [DIST]+[REC]

 In case, you have entered coordinates by ENH and measured to known points a plausibility check informs you about the calculated line length, the actual length and the difference.

**As built check:**

This dialog shows you the ▲Line, ▲Offset and ▲Height of a measured point in relation to the line.

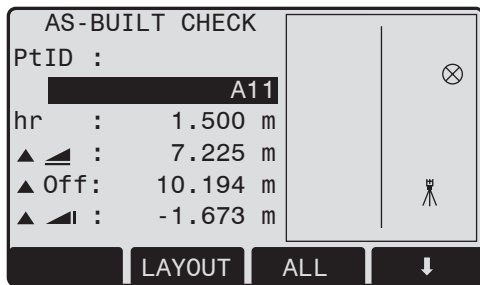

[ShiftLn] Allows you to enter values for shifting the line.

[LAYOUT] Switches to Layout-mode.

▲Line is positive:

Measured point is in direction from line start - to line end point.

▲Offset is positive:

Measured point is right of line.

▲Height is positive:

Measured point height is above line start point's height.

 The height of the line start point is always used as the reference height!

## Layout

Here you can search or enter points for staking out related to the measured line.

LAY-OUT			
PtID :			×
	A11		
hr :	1.500 m		⊗
▲ ▲ :	7.218 m	↑	17.000 m
▲ Off:	10.192 m	←	0.000 m
▲ ▲   :	-1.673 m	↓	1.500 m
INPUT	AsBUILT	ALL	↓

[ShiftLn] Allows you to enter values for shifting the line.

[AsBUILT] Switches to AsBuilt-mode.

The graphics show you the position of the prism related to the stake out point. Below, the exact

values are displayed, combined with arrows to show the direction.

▲Line is positive (arrow up):

Target point is further away than the measured point.

▲Offset is positive (arrow right):

Target point is right of the measured point.

▲Height is positive (arrow up):

Target point is higher than the measured point.

 The height of the line start point is always used as the reference height!

 The graphics are scaled to give a better overview. Therefore it's possible that the station point moves in the graphics.

 Be aware that the line start point and the line end point are measured in the previous coordinate system. When staking out this points they appear in the old system and appear as shifted.

 During use of the application the previous Orientation and Station parameters will be replaced by the new calculated ones.

## 2D-Road (optional)

 The application Road Alignment can be started in total 40 times for trial. Afterwards you have to enter the license code.

This program allows you easily to define a line or curve or spiral as a reference for measurements and stake outs. It supports chainages, as well as incremental stake outs and offsets (right/left).

### Procedure:

1. Select Element  
Choose, if you want to define a LINE, a CURVE or a SPIRAL.
2. Define Element
  - a) Line - Measure or select the start- and endpoint.
  - b) Curve - Measure or select the start- and endpoint, enter the radius and curve direction.

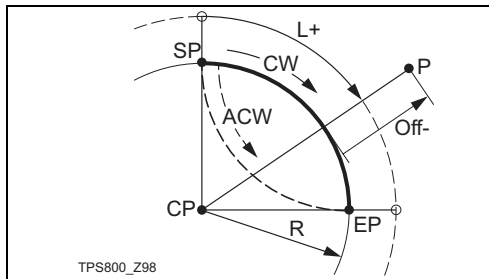

- P: Point to stake  
R: Radius of circle  
L: Distance from start of arc, following curve  
Off: Perpendicular distance from arc  
CW: Clockwise  
ACW: Anti-clockwise

- c) Spiral - Measure or select the start- and endpoint, select the data to be entered (Radius & Parameter or Radius & Length), type (Spiral In/Spiral Out) and direction (clockwise, anti-clockwise).

```

2D ROAD
Select Method and enter data !
Method      :      Rad/Par. ◀▶
Radius      :      400.000 m
Parameter   :      600.000 m
Length      :      900.000 m
Direction   :      Clk-wise ◀▶
Type        :      Spir.In ◀▶
PREV      [ ] [ ] [ ] OK
  
```

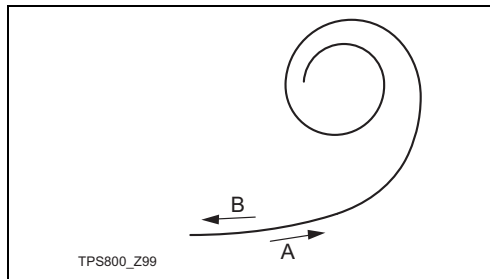

- A: Spiral In  
B: Spiral Out

- Entry of chainage and how to proceed  
Enter the chainage of the start point.  
(e.g. 100.000)  
[MEASURE] Starts the subapplication "Measure Chainage and Offset".  
[STAKE] Starts the subapplication "Stake Out".

## "L&O" subapplication

Here you can measure or select points from memory and you will see the Chainage, Line and Offset referring to the defined object.

## "Stake Out" subapplication

### Procedure:

1. Define the Stake Out point(s)  
Input the Chainage, Line and Offset of the stake out point. Optional you can enter a height and a increment as well.
2. Stake Out the point(s)  
Here you can select the point and offset (center, left, right) you want to stake out and start the measurement. The correction from actual point to stake out point is shown on the display.

Enter stakeout values	
Chainage :	1100.000 m
Offs.Left :	5.000 m
Offs.Right :	4.000 m
Increment :	10.000 m
Height :	0.000 m

PREV    RESET    OK

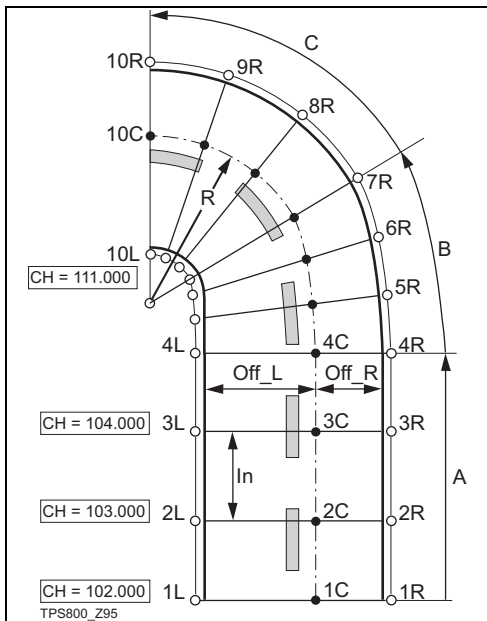

A: Line  
 B: Spiral  
 C: Curve

1L ... 10L Left point of road  
 1C ... 10C Center point of road  
 1R ... 10R Right point of road

CH: Chainage  
 Off\_L: Offset left  
 Off\_R: Offset right  
 R: Radius of curve (and spiral)

## COGO (optional)

 The application COGO can be started in total 40 times for trial. Afterwards you have to enter the license code.

COGO is an application program to perform **coordinate geometry** calculations such as:

- coordinates of points
- bearings between points
- distances between points

The COGO calculation methods are:

- Inverse
- Intersection
- Traverse

### Softkeys:

- [MEAS] Jumps to the Measurement dialog to measure the point.
- [Calc] Starts the calculation, when all required data are entered.
- [STAKE] When the calculated point is displayed you have the option to stake our this point directly.

## Inverse & Traverse

### Inverse

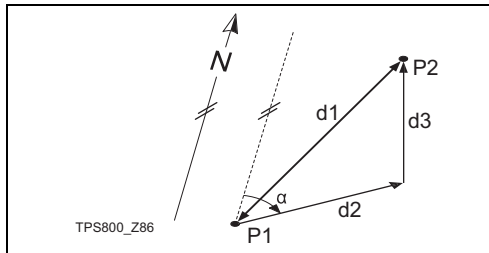

### Known

P1 First known point

P2 Second known point

### Unknown

$\alpha$  Direction from P1 to P2

d1 Slope distance between P1 and P2

d2 Horizontal distance between P1 and P2

d3 Height difference between P1 and P2

## Traverse

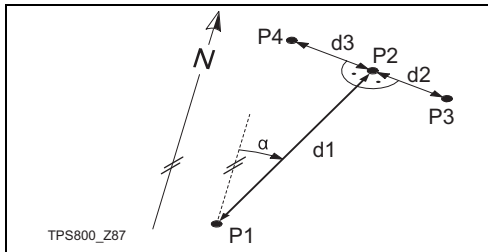

### Known

P1 Known point

$\alpha$  Direction from P1 to P2

d1 Distance between P1 and P2

d2 Positive offset to the right

d3 Negative offset to the left

### Unknown

P2 COGO point without offset

P3 COGO point with positive offset

P4 COGO point with negative offset

## Intersections

### Bearing - Bearing

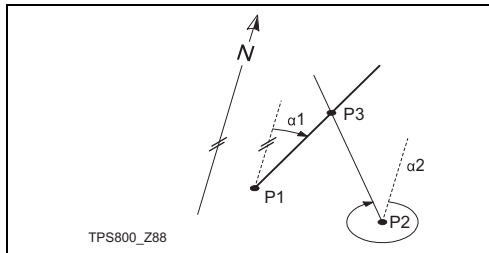

### Known

P1 First known point

P2 Second known point

$\alpha1$  Direction from P1 to P3

$\alpha2$  Direction from P2 to P3

### Unknown

P3 COGO point

## Bearing - Distance

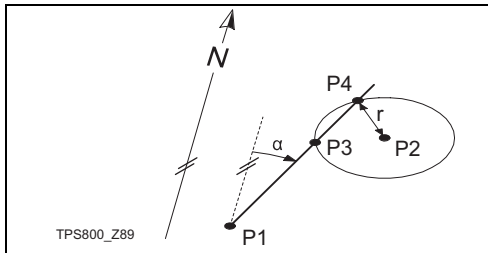

### Known

P1 First known point

P2 Second known point

$\alpha$  Direction from P1 to P3 and P4

r Radius, as defined by the distance from P2 to P4 and P3

### Unknown

P3 First COGO point

P4 Second COGO point

## Distance - Distance

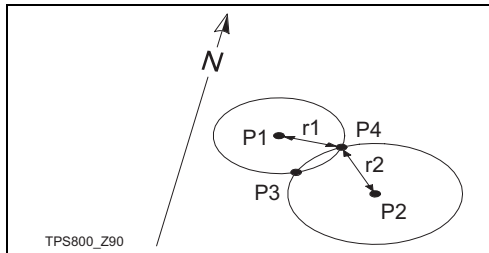

### Known

P1 First known point

P2 Second known point

r1 Radius, as defined by the distance from P1 to P3 or P4

r2 Radius, as defined by the distance from P2 to P3 or P4

### Unknown

P3 First COGO point

P4 Second COGO point

## By Points

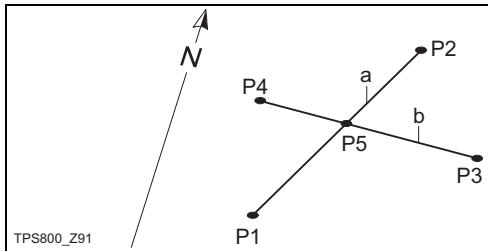

### Known

- P1 First known point
- P2 Second known point
- P3 Third known point
- P4 Fourth known point
- a Line from P1 to P2
- b Line from P3 to P4

### Unknown

- P5 COGO point

## Offset

### Distance - Offset

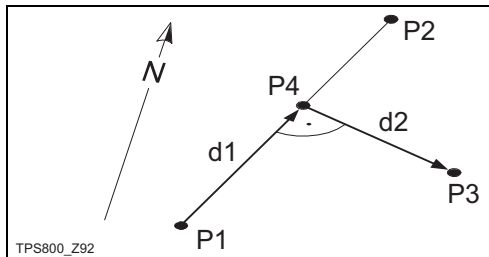

### Known

- P1 Baseline start point
- P2 Baseline end point
- P3 Lateral point

### Unknown

- a Difference in length/abzissa (HD)
- b Lateral deviation/ordinate (Offset)
- P4 Base point

## Set Point by ...

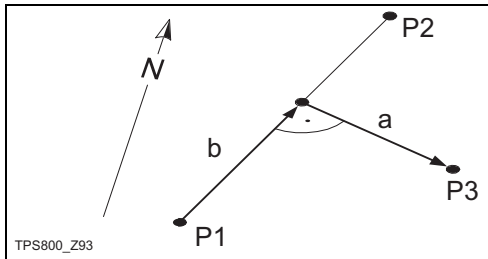

### Known

P1 Baseline start point

P2 Baseline end point

a Difference in length/abzissa (HD)

b Lateral deviation/ordinate (Offset)

### Unknown

P3 Lateral point

## Extention

The "Extention" routine computes extend point from base line.

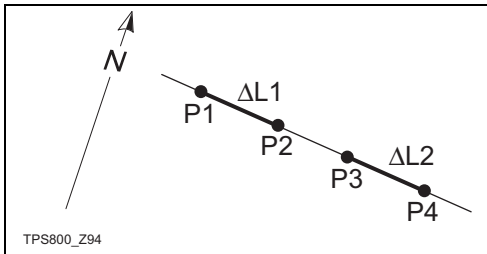

### Known

P1

Baseline start point

P3

Baseline end point

▲L1 or ▲L2

Distance

### Unknown

P2, P4

Extended point

---

## Coding

Codes contain information about recorded points. With the help of coding, points can be assigned to a particular group simplifying later processing. More information on coding can be found under "Data management".

### GSI-coding

Code: Code name  
Desc.: Additional remark  
Info1: more, freely editable  
... information  
Info8: lines

### Procedure:

1. Move cursor to field "Code".
2. Input code.
3. [ALL] Starts the distance measurement and saves the values including the entered code.  
  
[CODE] Searches for the entered code and offers the option of adding attributes.

CODE (FIND/SELECT)	
Find:	T*
Code:	TR1
Desc:	Border Line

AddList RECORD SET

- [SET] Sets the code block.  
[AddList] Adds an entered code into codelist.  
[RECORD] Closes the code entry or code selection and saves the code block.

## Manual code input

Individual code blocks can be entered directly via keypad.

ATTRIBUTE ENTRY	
Info1 :	-----
Info2 :	-----
Info3 :	-----
Info4 :	-----
<b>INPUT</b>	<b>SET</b>

1. [INPUT] Enter desired code.
2.  Confirm with ENTER.
3. Enter the attributes 1-8.
4. [SET] Sets the code block.

## Extending / editing code

1. Call available code from code list.
2. Attributes can be overwritten freely.

Exceptions:

With the codelist editor of LGO a status can be assigned to the attributes.

- Attributes with "fixed status" (see LGO) are write-protected. They cannot be overwritten or edited.
- For attributes with status "Mandatory" an input or a confirmation is required.
- Attributes with status "Normal" can be edited freely.

## Recording code block

[SET] Sets the code block temporarily in the system after ending the code functions. Recording only with measurement and always with reference to the actual point number.

## **Quick Code**

Using the quick code function, a predefined code can be called directly via the numeric keypad on the instrument. The code is selected by entering a two digit number, the measurement triggered and the measured data and code saved.

A total of 100 codes can be assigned.

Each code can be assigned a unique one or two digit number in the "Codelist Manager".

If no numbers are allocated to the codes in the "Codelist Manager", the code is selected in accordance with the order in which the codes were entered in the code list (01 -> first code in the code list ... 10 -> tenth code in the code list).

### **Procedure:**

1. Press the [Q-Code] button to activate Quick coding.
2. Enter a two digit number on the numeric keypad -> code is selected, the measurement triggered and the measured data and code saved.

The name of the selected code is displayed after the measurement.

A two digit code must always be entered on the instrument's numeric keypad even if only a one digit code was assigned in the Codelist Manager.

For example: 4 -> enter 04.



To end Q-Coding press the [Q-Code] button again.

## Warnings / Messages

Important Messages	Meaning
Attrib. cannot be changed !	Attribute with fixed status cannot be changed.
No codelist available !	No codelist in memory. Manual input for code and attributes are called automatically.
Entry required !	Code missing. Extend input.



Individually entered code blocks are not added to the code list.

### Leica Geo Office Tools (LGO-Tools)

Codelists can be easily created and uploaded to the instrument using the supplied "LGO-Tools" Software.

# Settings

This menu enables extensive user-specific settings in order to adapt the instrument to their own requirements.

## Contrast

Setting the display contrast in 10% steps.

## Trigger key

Configuration of the trigger key on side cover.

Off	Trigger key deactivated.
ALL	Trigger key with same function as the [ALL]-key.
DIST	Trigger key with same function as the [DIST]-key.

## USER Key

Configure the USER Key with a function from the FNC-menu.

## V-Setting

The "0"- orientation of the vertical circle can be either selected for the zenith, the horizontal plane or in %.

- Zenith:Zenith=0°; Horizon=90°
- Horizon: Zenith=90°; Horizon=0°
- V-(%): 45°=100%; Horizon=0°



The % value increases rapidly. "--.--%" appears on the display above 300%".

## Tilt Correction

Off	Tilting compensation switched off.
1-axis	V-angles relate to the plumb line.
2-axis	V-angle refer to the plummet line and the Hz-directions are corrected by the standing axis tilt.

If the instrument is used on an unstable base (e.g. shaking platform, ship, etc.) the compensator should be switched off.

This avoids the compensator drifting out of its measuring range and interrupting the measuring process by indicating an error.



The compensator setting remains active even after the instrument is switched off.

## Sector Beep

- Off Sector Beep switched off  
On Sector Beep sounds at right angles ( $0^\circ$ ,  $90^\circ$ ,  $180^\circ$ ,  $270^\circ$  or 0, 100, 200, 300 gon)

### Example Sector Beep:

From  $95.0$  to  $99.5$  gon (or from  $105.0$  to  $100.5$  gon) a "Fast beep" sounds whilest from  $99.5$  to  $99.995$  gon (or from  $100.5$  to  $100.005$  gon) a "Permanent beep" sounds.

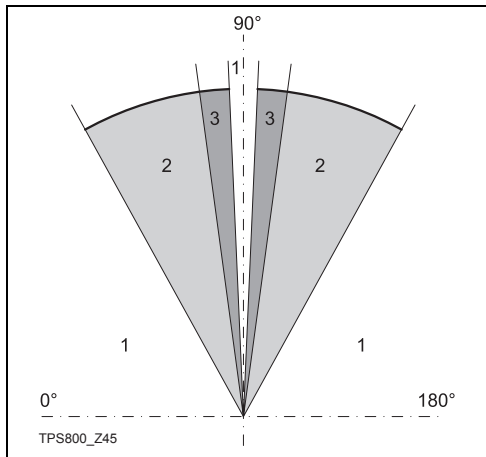

- 1) No beep
- 2) Fast beep (interrupted)
- 3) Permanent beep

## Beep

The beep is an acoustic signal after each key stroke.

Off	Beep switched off
Normal	Normal volume
Loud	Increased volume

## Hz Incrementation

Right	Set right Hz for "Clockwise direction measurement".
Left	Set left Hz for "Counter-clockwise direction measurement". "Counter-clockwise" directions are only displayed but saved as "Clockwise direction".

## Reticle Illumination

The reticle illumination is only switched on if the display illumination is on.

Low	Low illuminaton
Medium	Medium illuminaton
High	High illuminaton

## Display Heater

On	Is automatically activated when the display illumination is on and the instrument temperature is $\leq 5^{\circ}\text{C}$ .
----	---

## Data Output

RS232	Data is recorded via the serial interface. For this purpose, a data storage device must be connected.
Intern	All data is recorded in the internal memory.

## GSI 8/16

Select GSI output format.

GSI 8:	81..00+12345678
GSI 16:	81..00+1234567890123456

## Mask 1/2

Select GSI output mask.

Mask 1:	PtID, Hz, V, SD, ppm+mm, hr, hi
Mask 2:	PtID, Hz, V, SD, E, N, H, hr

## Hz Collimation

On Hz Collimation is switched ON.

Off Hz Collimation is switched OFF.

**If option "Hz Collimation ON" is active, each measured Hz-angle is corrected (depending on V-angle).**

For normal operation the Hz-collimation remains switched on.



More information on Hz-collimation can be found under "Adjustments".

## Auto-OFF

**Enable** The instrument is switched off after 20 minutes without any action (= no key pressed; V and Hz angle deviation  $\leq \pm 3' / \pm 600''$ ).

**Disable** The instrument is switched on permanently. Battery discharges quicker.

**Sleep** Economy mode. Instrument is recovered by any key stroke.

## Min. Reading

The displayed angle format can be selected in three steps.

- **For 360<sup>0000</sup>:**  
0° 00' 01" / 0° 00' 05" / 0° 00' 10"  
Always " are indicated.
- **For 360°:**  
0.0005° / 0.001° / 0.005°
- **For gon:**  
0.0005 gon / 0.001 gon / 0.005 gon
- **For mil:**  
0.01 mil / 0.05 mil / 0.10 mil

## Angle Unit

° ' "	(degree sexagesimal) possible angle values: 0° to 359°59'59"
DD	(degree decimal) possible angle values: 0° to 359.999°
gon	possible angle values: 0 gon to 399.999 gon
mil	possible angle values: 0 to 6399.99mil

The setting of the angle units can be changed at any time.

The actual displayed values are converted according to the selected unit.

## Distance Unit

meter	Meter
ft-in1/8	US-feet-Inch-1/8 inch
US-ft	US-feet
INT-ft	International feet

## Temperature

°C	Degree Celsius
°F	Degree Fahrenheit

## Pressure

mbar	Millibar
hPa	Hecto Pascal
mmHg	Millimeter mercury column
inHg	Inch mercury column

## Face I Definition

Defines the telescope face I in relation to the position of the Vdrive.

## Code Record

Sets if the codeblock is saved before or after the measurement (see chapter "Coding").

## EDM Settings

The EDM-settings contain a detailed menu with selection boxes.

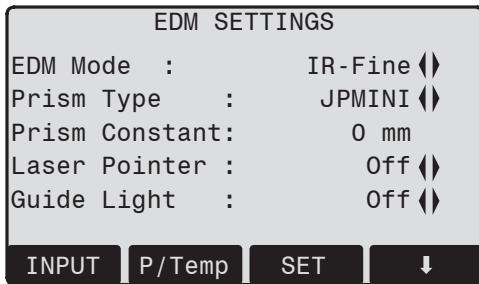

### EDM Mode

With TCR instruments different settings for measurements with visible (RL) and invisible (IR) EDM type are available.

Depending on selected measuring mode the selection prism types are different.

IR-Fine	Fine measuring mode for high precision measurements with prisms (2mm + 2 ppm)
IR-Fast	Quick measuring mode with higher measuring speed and reduced accuracy (5mm + 2 ppm)
IR-Track	Continuous distance measuring (5mm + 2 ppm)
IR-Tape	Distance measurement using Retro targets (5mm + 2 ppm)



RL-Short	Short range. For distance measurements without prisms (3mm + 2 ppm)
RL-Track	Continuous distance measurement without prisms (5mm + 2 ppm)
RL-Prism	Long range. For distance measurements with prisms (5mm + 2 ppm)

 With the RL-EDM each object in the beam is measured (possibly also branches, cars, etc.).

### Prism type

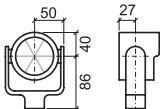
Calling the function in the EDM settings.

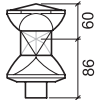
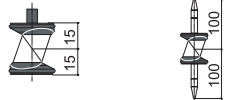
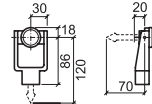
Leica Prisms	Constants [mm]	
Standard prism GPH1 + GPR1	0.0	

Leica Prisms	Constants [mm]	
360° prism GRZ4	+23.1	
360° Mini prism GRZ101	+30.0	
Miniprism GMP101/102	+17.5	
JPMINI	+34.4	Mini prism
Reflective targets	+34.4	
USER	--	is set at "Prismconst" (-mm + 34.4; e.g.: mm = 14 -> input = -14 + 34.4 = 20.4)
RL	+34.4	Reflectorless

### Prism Constant

Calling the function in the EDM settings.

Entry of a user specific prism constant. Input can only be made in [mm].

Limit value: -999 mm to +999 mm

### Laser Pointer

Off: Visible laser beam is switched off.

On: Visible laser beam for visualising the target point is switched on.

### Guide Light

The person at the prism can be guided by the flashing lights directly to the line of sight. The light points are visible up to a distance of 150 meters. This is useful when stake out points.

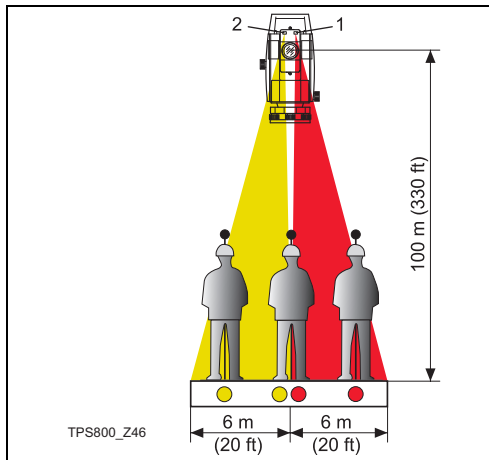

- 1) Flashing red diode
- 2) Flashing yellow diode

Operat. range: 5 - 150 m (15 -500 ft)

Divergence: 12 m (40 ft) at 100 m (330 ft)

### [SCALE]

Scale of projection.

PROJECTION SCALE		
Enter scale factor !		
Scale factor:	1.000060	
Scale ppm :	60	
PREV	PPM=0	OK

### Scale factor:

Entering the scale of projection. Measured values and coordinates are corrected with the PPM parameter.

[PPM=0] Sets default parameters.

### [PPM]

Input of individual scaling parameters.

### [ATMOS]

Input of atmospheric parameters.

Atmospheric Parameters (ppm):

Distance measurement is influenced directly by the atmospheric conditions of the air in which distance measurement are taken.

ATMOSPHERIC DATA (PPM)			
Ht. a. MSL :	500 m		
Temperature:	16 °C		
Pressure :	952 hPa		
Atmos PPM :	21 PPM		
INPUT	PREV	PPM=0	SET

In order to take into consideration these influences distance measurements are corrected using atmospheric correction parameters.

- Ht. a. MSL  
Height above sea level at instrument location.
- Temperature  
Air temperature at instrument location.
- Pressure  
Air pressure at instrument location.
- Atmos PPM:  
Calculated and indicated atmospheric PPM.
- Refr.Coeff:  
Input of refraction coefficient for the atmospheric conditions.

### **Refraction correction**

The refraction correction is taken into account in the calculation of the height differences and the horizontal distance.

### **Signal**

[SIGNAL] Displays EDM signal strength (reflection strength) in steps of 1%. Permits optimal aiming at distant barely visible targets.

## File Management

The File Manager contains all functions for entering, editing and for checking data in the field.

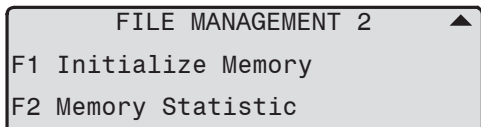
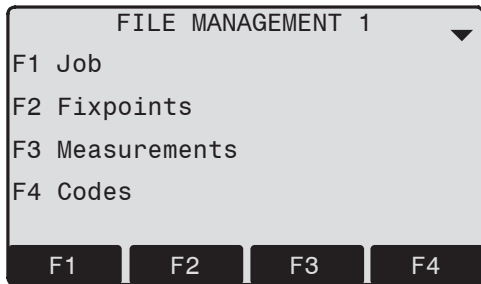

### Job

Jobs are a summary of data of different types, e.g. fixed points, measurements, codes, results, etc.

The job definition consists of the input of job name and user.

Additionally, the system generates time and date at the time of creation.

### Job search:



Scrolling through jobs.

[DELETE]

Deletes selected job.

[SET]

Sets the selected job.

[NEW]

Starts new job.

## Fixpoints

Valid fixed points contain at least the PtID and the coordinates (E, N) or (H).

- [DELETE] Deletes selected fixed point.
- [FIND] Starts point search. Exact PtIDs can be entered or the \* wildcard-criteria used.
- [NEW] Opens input for PtID and coordinates.

## Measurements

Measurement data available in the internal memory can be searched and displayed or erased.

- [FIND] Starts point search dialogue.
- [VIEW] Displays all measurements.

## Codes

To each code a description and a maximum of 8 attributes with up to 16 characters can be assigned.

INPUT CODELIST	
Code:	Nr01 ◀▶
Desc:	border line

SAVE VIEW ATTRIB

Info1:	Nr. 123
Info2:	12.54
Info3:	

- [SAVE] Save data.
- [VIEW] Starts search dialogue.
- [ATTRIB] Input of attributes.

## Initialize Memory

Deletes jobs, single data areas of a job or all data.

[DELETE]      Starts deleting process within the selected area.

[ALL]          Deletes all data in memory. All data will be lost !



Deleting the memory cannot be undone. After confirming the message all data is deleted permanently.

## Memory Statistic

Displays job specific memory information such as:

- Number of stored fixpoints.
- Number of recorded data blocks (measured points, codes, etc.).
- Number of free or not defined jobs.

## Start-up sequence

Sets the screen the instrument starts in when switched on. E.g. the electronic bubble can be displayed at every start.

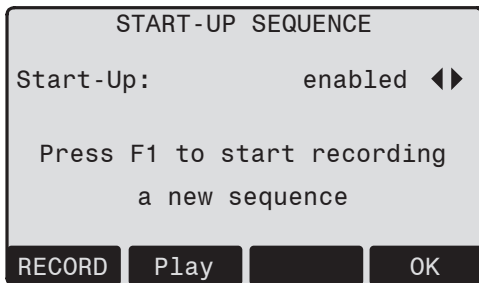

- [OK] Stores current settings.
- [RECORD] Defines the key presses that are executed automatically upon start up.
- [Play] Starts to run the recorded sequence.

### Procedure:

After confirming the dialogue of notification, the "Meas & Rec" screen is displayed. A maximum of 16 of the next key presses are stored. The sequence is ended with [ESC]. If the start sequence is activated, the stored key presses are executed automatically when the instrument is switched on.



The automatic start sequence has the same effect as pressing the keys manually. Certain instrument settings can not be made in this way. "Relative entries" such as automatically setting "IR-FINE" upon switching on the instrument, are not possible.

## Check & Adjust

### Determining Line-of-sight error and V-Index

The adjustment contains the determination of the following instrument errors:

- Hz-collimation
- V-index (simultaneously electronic level)

For determining the Hz-collimation or the V-index it is necessary to measure in both telescope positions. The procedure can be started in any telescope position.

The user is guided clearly through the procedure. A wrong determination of instrument error is thus eliminated.

The instruments are adjusted in the factory prior to shipping.

Instrument errors can change with time and temperature.



These errors should be determined before the instrument is used for the first time, before precision surveys, after long periods of transport, before and after long periods of work, and if the temperature changes by more than 10°C (18°F).



Before determining the instrument errors, level-up the instrument using the electronic bubble. The instrument should be secure and firm, and should be protected from direct sunlight in order to avoid thermal expansion on one side only.



Before starting to work, the instrument has to become acclimatised to the ambient temperature. Approximately two minutes per °C of temperature difference from storage to working environment but at least 15 min should be taken into account.

## Line-of-sight error (Hz-collimation)

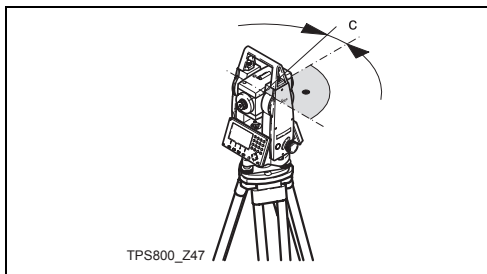

The line-of-sight error or collimation error (C) is the deviation from the perpendicular between the tilting axis and the line of sight.

The effect of the line-of-sight error to the Hz-angle increases with the vertical angle.

For horizontal aimings the error of Hz equals the line-of-sight error.

## V-Index (Vertical index error)

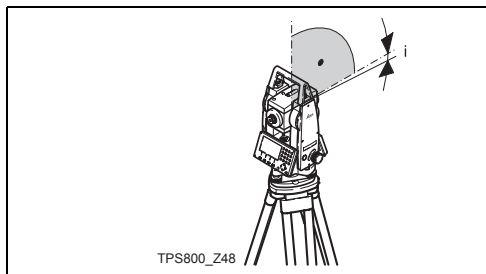

The vertical circle should read exactly  $90^\circ$  (100 gon) when the line of sight is horizontal. Any deviation from this figure is termed vertical index error (i). By determining the vertical index error the electronic level is adjusted automatically.

 Procedures and conditions required to correct line-of-sight and height index errors are the same. Thus the procedure will only be described once.

- F1** Hz-collimation
- F2** V-index
- F3** Display adjustment value:  
Summarizes saved values.

**Procedure:**

1. Level instrument with electronic bubble.
2. Aim at a point approximately 100m from the instrument which is within  $5^\circ$  of the horizontal.

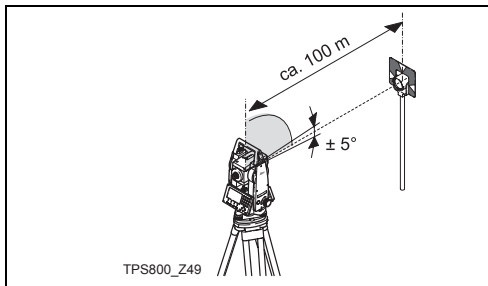

3. [ALL]: Trigger measurement.
4. Change telescope position and aim to the point again.

For checking the horizontal aiming Hz and V are displayed.

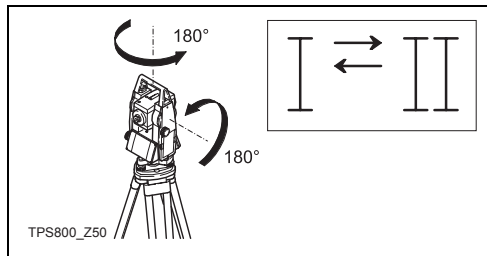

5. [ALL]: Starts measurement
6. Displays the old and new calculated values.
  - [SET] Sets new adjustment data.
  - [ESC] Quits program without setting new adjustment data.

## Warnings / Messages

Important Messages	Meaning	Measures
V-Angle not suitable for adjustment (Check V-angle or face) !	Aiming tolerance not met or telescope position/face not changed.	Aim on the target point with an accuracy of min. 5 gon. The target point must be approximately in the horizontal plane. Confirmation of the message required.
Adjustment result out of tolerance. Previous values retained !	Computed values out of tolerance. Previous values retained.	Repeat measurements. Confirmation of the message required.
Hz-Angle out of limit !	Hz-angle in second face/telescope pos. deviates more than 5 gon from the target point.	Aim on the target point with an accuracy of min. 5 gon. Confirmation of the message required.
Measurement Error. Try again.	Measurement error appeared (e.g. instable set up or period between measuring in telescope position I and II too long).	Repeat the process. Confirmation of the message required.

## Tripod

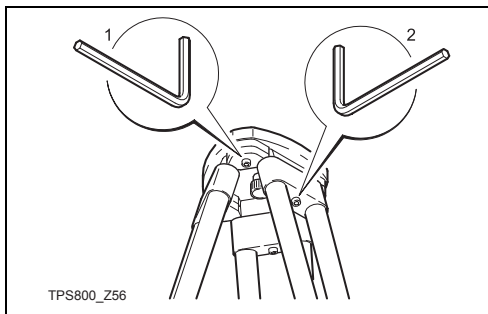

The connections between metal and timber components must always be firm and tight.

- Tighten the Allen screws (2) moderately.
- Tighten the articulated joints on the tripod head (1) just enough to keep the tripod legs open when you lift it off the ground.

## Circular level

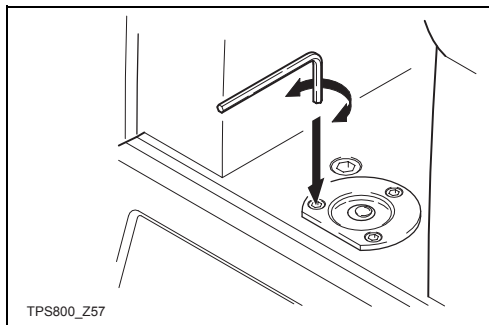

Level-up the instrument in advance with the electronic level. The bubble must be centered. If it extends beyond the circle, use the Allen key supplied to center it by turning the adjustment screws. After adjustment no screw must be loose.

## Circular level on the tribrach

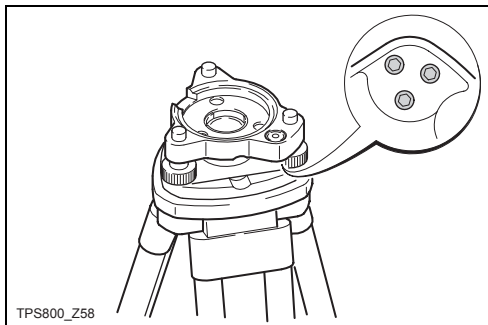

Level the instrument and then remove it from the tribrach. If the bubble is not centred, adjust it using the adjusting pin.

Turning the adjustment screws:

- to the left: the bubble approaches the screw
- to the right: the bubble goes away from the screw.

After adjustment no screw must be loose.

## Laser plummet

The laser plummet is integrated into the vertical axis of the instrument. Under normal circumstances setting of the laser plummet is not necessary. If an adjustment is necessary due to external influences the instrument has to be returned to any Leica service department.

### Checking by turning the instrument by 360°:

1. Install the instrument on the tripod approx. 1.5 m above ground and level up.
2. Switch on laser plummet and mark the centre of the red spot.
3. Turn instrument slowly by 360° and observe the red laser dot.

Inspecting the laser plummet should be carried out on a bright, smooth and horizontal surface (e.g. a sheet of paper).

If the centre of the laser dot makes a clearly circular movement or if the centre of the point is moving away more than 3 mm from the first marked point an adjustment is possibly necessary. Call your nearest Leica service department.

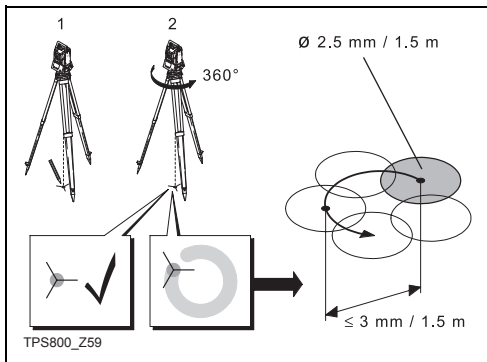

Depending on brightness and surface the size of the laser dot can vary. At a distance of 1.5 m an average value of 2.5 mm diameter must be estimated.

The maximum diameter of the circular movement described by the centre of the laser point should not exceed 3 mm at a distance of 1.5m.

## Reflectorless EDM

The red laser beam used for measuring without reflector is arranged coaxially with the line of sight of the telescope, and emerges from the objective port. If the instrument is well adjusted, the red measuring beam will coincide with the visual line of sight. External influences such as shock or large temperature fluctuations can displace the red measuring beam relative to the line of sight.

 The direction of the beam should be inspected before precise measurement of distances is attempted, because an excessive deviation of the laser beam from the line of sight can result in imprecise distance measurements.

### Warning

Direct intrabeam viewing is always hazardous.

### Precautions:

Do not stare into the beam or direct it towards other people unnecessarily. These measures are also valid for the reflected beam.

## Inspection

A target plate is provided. Set it up between five and 20 metres away with the grey reflective side facing the instrument. Move the telescope to face II. Switch on the red laser beam by activating the laser-point function. Use the telescope crosshair to align the instrument with the centre of the target plate, and then inspect the position of the red laser dot on the target plate. Generally speaking the red spot cannot be seen through the telescope, so look at the target plate from just above the telescope or from just to the side of it.

If the spot illuminates the cross, the achievable adjustment precision has been reached; if it lies outside the limits of the cross, the direction of the beam needs to be adjusted.

If the spot on the more reflective side of the plate is too bright (dazzling), use the white side instead to carry out the inspection.

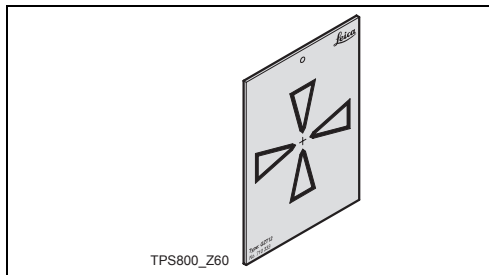



## Adjusting the direction of the beam

Pull the two plugs out from the adjustment ports on the top side of the telescope housing.

To correct the height of the beam, insert the screwdriver into the rear adjustment port and turn it clockwise (spot on target plate moves obliquely upwards) or anticlockwise (spot moves obliquely downwards).

To correct the beam laterally, insert the screwdriver into the front adjustment port and turn it clockwise (spot moves to the right) or anticlockwise (spot moves to the left).

 Throughout the adjustment procedure, keep the telescope pointing to the target plate.

 After each field adjustment, replace the plugs in the adjustment ports to keep out damp and dirt.

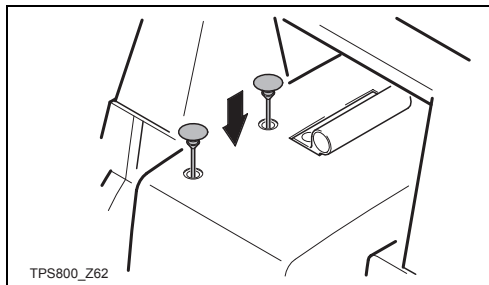
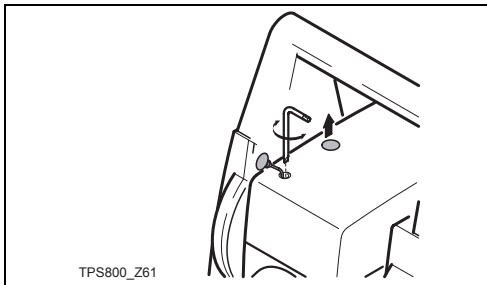

## COMM Parameters

For data transfer between PC and instrument the communication parameters of the serial interface RS232 must be set.

### Leica Standard setting

19200 Baud, 8 Databit, No Parity, 1 Stopbit, CR/LF

### Baudrate

Data transfer speed 2400, 4800, 9600, 19200 [bits / second]

### Databits

- 7 Data transfer is realized with 7 databits. Is set automatically if parity is "Even" or "Odd".
- 8 Data transfer is realized with 8 databits. Is set automatically if parity is "None".

### Parity

- Even Even parity
- Odd Odd parity
- None No parity (if data bit is set to 8)

### Endmark

- CRLF Carriage return; line feed

CR Carriage return

### Stopbits

Fixed setting 1.

### Interface plug connections:

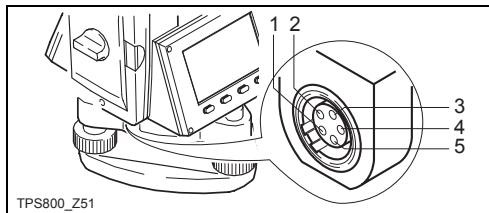

- 1) External battery
- 2) Not connected / inactive
- 3) GND
- 4) Data reception (TH\_RXD)
- 5) Data transfer (TH\_TXD)

TH ... Theodolite

## Data Transfer

With this special function measured data can be transferred via the serial interface to a receiver (e.g. a Laptop). Using this type of transfer the success of the transfer is **not** checked.

**Job:** Selection of job from which data should be transferred.

**Data:** Select the data range to be transferred (measurements, fixed points)

**Format:** Select output format. Select Leica-GSI-format, or your own format created in the "Format Manager" and transfer to the LGO.

**[SEND]** Starts the transmission.

### Example:

Within the "data" setting "MEASUREMENTS" a data set could be shown as follows:

**11**...+00000D19    **21**..022+16641826  
**22**..022+09635023    **31**..00+00006649  
**58**..16+00000344    **81**..00+00003342  
**82**..00-00005736    **83**..00+00000091

**87**..10+00001700



If the receiver is too slow in processing data the data could be lost. With this type of data transfer the instrument is not informed about the performance of the receiver (no protocol).

GSI-ID's		
11	△	PtID
21	△	Horizontal direction
22	△	Vertical angle
31	△	Slope distance
32	△	Horizontal distance
33	△	Height difference
41-49	△	Codes and attributes
51	△	ppm [mm]
58	△	Prism constants
81-83	△	(E, N, H) Target point
84-86	△	(E, N, H) Stand point
87	△	Reflector height
88	△	Instrument height

## System Info

Displays helpful information and date / time are set. [SW-Info]

- **Battery**  
Remaining battery power (e.g. 40%).
- **Instr.Temp.**  
Measured instrument temperature.
- **Date**  
Displays the current date.
- **Time**  
Displays current time.

[DATE] Change date and format.

Format: There are three display formats:

- DD.MM.YYYY
- MM.DD.YYYY
- YYYY.MM.DDT

Date: Input date

[TIME] Set time.

The software of the instrument is composed of different software packages. Depending on the package, different versions are possible.

Op-System: Operating System

App.-SW: Applications, functions and menu

Layout: User displays

# Care and Transport

## Transport

### Transport in the field

When transporting the equipment in the field, always make sure that you

- either carry the product in its original transport container,
- or carry the tripod with its legs splayed across your shoulder, keeping the attached product upright.



TPS800\_Z52

### Transport in a road vehicle

Never carry the product loose in a road vehicle, as it can be affected by shock and vibration. Always carry the product in its transport container and secure it.

## Shipping

When transporting the product by rail, air or sea, always use the complete original Leica Geosystems packaging, transport container and cardboard box, or its equivalent, to protect against shock and vibration.

### Shipping, transport of batteries

When transporting or shipping batteries, the person in charge of the product must ensure that the applicable national and international rules and regulations are observed. Before transportation or shipping, contact your local passenger or freight transport company.

### Field adjustment

After transport inspect the field adjustment parameters given in this user manual before using the product.

---

## **Storage**

### **Product**

Respect the temperature limits when storing the equipment, particularly in summer if the equipment is inside a vehicle. Refer to "Technical Data" for information about temperature limits.

### **Field adjustment**

After long periods of storage inspect the field adjustment parameters given in this user manual before using the product.

## **Batteries**

- Refer to "Technical Data" for information about storage temperature range.
- The permissible temperature range for storing is  $-40^{\circ}\text{C}$  to  $+55^{\circ}\text{C}$  /  $-40^{\circ}\text{F}$  to  $+131^{\circ}\text{F}$ . We recommend a storage temperature range of  $0^{\circ}\text{C}$  to  $+20^{\circ}\text{C}$  /  $+32^{\circ}\text{F}$  to  $68^{\circ}\text{F}$  in dry environment to minimize self-discharging.
- At the recommended storage temperature range, batteries containing a 10% to 50% charge can be stored for up to one year. After this storage period the batteries must be recharged.
- Remove batteries from the product and the charger before storing.
- After storage recharge batteries before using.
- Protect batteries from damp and wetness. Wet or damp batteries must be dried before storing or use.

---

## **Cleaning and Drying**

### **Objective, eyepiece and prisms**

- Blow dust off lenses and prisms.
  - Never touch the glass with your fingers.
  - Use only a clean, soft, lint-free cloth for cleaning. If necessary, moisten the cloth with water or pure alcohol.
- Do not use other liquids; these may attack the polymer components.

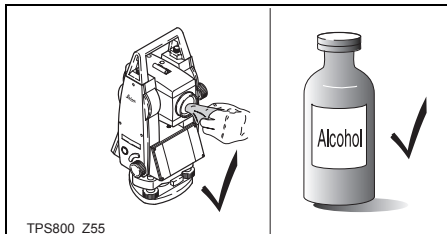

### **Fogging of prisms**

Reflector prisms that are cooler than the ambient temperature tend to fog. It is not enough simply to wipe them. Keep them for some time inside your jacket or in the vehicle to allow them to adjust to the ambient temperature.

### **Damp products**

Dry the product, the transport container, the foam inserts and the accessories at a temperature not greater than 40°C / 108°F and clean them. Do not repack until everything is completely dry.

### **Cables and plugs**

Keep plugs clean and dry. Blow away any dirt lodged in the plugs of the connecting cables.

## ***Safety Directions***

The following directions should enable the person responsible for the product, and the person who actually uses the equipment, to anticipate and avoid operational hazards.

The person responsible for the product must ensure that all users understand these directions and adhere to them.

### ***Intended Use***

#### ***Permitted use***

- Measuring horizontal and vertical angles.
- Measuring distances.
- Recording measurements.
- Computing by means of application software.
- Visualizing the aiming direction and vertical axis.
- Visualizing the target (with laser pointer).

#### ***Adverse uses***

- Use of the product without instruction.
- Use outside of the intended limits.
- Disabling safety systems.
- Removal of hazard notices.
- Opening the product using tools, for example screwdriver, unless this is specifically permitted for certain functions.
- Modification or conversion of the product.
- Use after misappropriation.

- Use of products with obviously recognizable damages or defects.
- Use with accessories from other manufacturers without the prior explicit approval of Leica Geosystems.
- Aiming directly into the sun.
- Inadequate safeguards at the surveying site, for example when measuring on roads.
- Deliberate dazzling of third parties.
- Controlling of machines, moving objects or similar monitoring application without additional control- and safety installations.



### **Warning**

Adverse use can lead to injury, malfunction and damage.

It is the task of the person responsible for the equipment to inform the user about hazards and how to counteract them. The product is not to be operated until the user has been instructed on how to work with it.

---

## **Limits of Use**

### **Environment**

Suitable for use in an atmosphere appropriate for permanent human habitation: not suitable for use in aggressive or explosive environments.



### **Danger**

Local safety authorities and safety experts must be contacted before working in hazardous explosive areas, or in close proximity to electrical installations or similar situations by the person in charge of the product.

---

## **Responsibilities**

### **Manufacturer of the product**

Leica Geosystems AG, CH-9435 Heerbrugg, hereinafter referred to as Leica Geosystems, is responsible for supplying the product, including the user manual and original accessories, in a completely safe condition.

### **Manufacturers of non Leica Geosystems accessories**

The manufacturers of non Leica Geosystems accessories for the product are responsible for developing, implementing and communicating safety concepts for their products, and are also responsible for the effectiveness of those safety concepts in combination with the Leica Geosystems product.

### **Person in charge of the product**

The person in charge of the product has the following duties:

- To understand the safety instructions on the product and the instructions in the user manual.
- To be familiar with local regulations relating to safety and accident prevention.
- To inform Leica Geosystems immediately if the product and the application becomes unsafe.



### **Warning**

The person responsible for the product must ensure that it is used in accordance with the instructions. This person is also accountable for the training and the deployment of personnel who use the product and for the safety of the equipment in use.

---

## ***International Warranty, Software Licence Agreement***

### **International Warranty**

The International Warranty can be downloaded from the Leica Geosystems AG home page at <http://www.leica-geosystems.com/internationalwarranty> or received from your Leica Geosystems dealer.

### **Software Licence Agreement**

This product contains software that is preinstalled on the product, or that is supplied to you on a data carrier medium, or that can be downloaded by you online pursuant to prior authorization from Leica Geosystems. Such software is protected by copyright and other laws and its use is defined and regulated by the Leica Geosystems Software Licence Agreement, which covers aspects such as, but not limited to, Scope of the Licence, Warranty, Intellectual Property Rights, Limitation of Liability, Exclusion of other Assurances, Governing Law and Place of Jurisdiction. Please make sure, that at any time you

fully comply with the terms and conditions of the Leica Geosystems Software Licence Agreement.

Such agreement is provided together with all products and can also be found at the Leica Geosystems home page at <http://www.leica-geosystems.com/swlicense> or your Leica Geosystems dealer.

You must not install or use the software unless you have read and accepted the terms and conditions of the Leica Geosystems Software Licence Agreement. Installation or use of the software or any part thereof, is deemed to be an acceptance of all the terms and conditions of such licence agreement. If you do not agree to all or some of the terms of such licence agreement, you may not download, install or use the software and you must return the unused software together with its accompanying documentation and the purchase receipt to the dealer from whom you purchased the product within ten (10) days of purchase to obtain a full refund of the purchase price.

---

## **Hazards of use**

### **Warning**

The absence of instruction, or the inadequate imparting of instruction, can lead to incorrect or adverse use, and can give rise to accidents with far-reaching human, material, financial and environmental consequences.

#### **Precautions:**

All users must follow the safety directions given by the manufacturer and the directions of the person responsible for the product.

### **Caution**

Watch out for erroneous measurement results if the product has been dropped or has been misused, modified, stored for long periods or transported.

#### **Precautions:**

Periodically carry out test measurements and perform the field adjustments indicated in the user manual, particularly after the product has been

subjected to abnormal use and before and after important measurements.

### **Danger**

Because of the risk of electrocution, it is very dangerous to use poles and extensions in the vicinity of electrical installations such as power cables or electrical railways.

#### **Precautions:**

Keep at a safe distance from electrical installations. If it is essential to work in this environment, first contact the safety authorities responsible for the electrical installations and follow their instructions.



### **Warning**

By surveying during a thunderstorm you are at risk from lightning.

#### **Precautions:**

Do not carry out field surveys during thunderstorms.

**Caution**

Be careful when pointing the product towards the sun, because the telescope functions as a magnifying glass and can injure your eyes and/or cause damage inside the product.

**Precautions:**

Do not point the product directly at the sun.

**Warning**

During dynamic applications, for example stakeout procedures there is a danger of accidents occurring if the user does not pay attention to the environmental conditions around, for example obstacles, excavations or traffic.

**Precautions:**

The person responsible for the product must make all users fully aware of the existing dangers.

**Warning**

Inadequate securing of the surveying site can lead to dangerous situations, for example in traffic, on building sites, and at industrial installations.

**Precautions:**

Always ensure that the survey site is adequately secured. Adhere to the regulations governing safety and accident prevention and road traffic.

**Warning**

If computers intended for use indoors are used in the field there is a danger of electric shock.

**Precautions:**

Adhere to the instructions given by the computer manufacturer with regard to field use in conjunction with Leica Geosystems products.

**Caution**

If the accessories used with the product are not properly secured and the product is subjected to mechanical shock, for example blows or falling, the product may be damaged or people may sustain injury.

**Precautions:**

When setting-up the product, make sure that the accessories, for example tripod, tribrach, connecting

cables, are correctly adapted, fitted, secured, and locked in position.

Avoid subjecting the product to mechanical stress.



**Caution**

During the transport, shipping or disposal of batteries it is possible for inappropriate mechanical influences to constitute a fire hazard.

**Precautions:**

Before shipping the product or disposing of it, discharge the batteries by running the product until they are flat.

When transporting or shipping batteries, the person in charge of the product must ensure that the applicable national and international rules and regulations are observed. Before transportation or shipping contact your local passenger or freight transport company.



**Warning**

Using a battery charger not recommended by Leica Geosystems can destroy the batteries. This can cause fire or explosions.

**Precautions:**

Only use chargers recommended by Leica Geosystems to charge the batteries.



**Warning**

High mechanical stress, high ambient temperatures or immersion into fluids can cause leakage, fire or explosions of the batteries.

**Precautions:**

Protect the batteries from mechanical influences and high ambient temperatures. Do not drop or immerse batteries into fluids.



**Warning**

Short circuited battery terminals can overheat and cause injury or fire, for example by storing or transporting in pockets if battery terminals come in contact with jewellery, keys, metallized paper or other metals.

**Precautions:**

Make sure that the battery terminals do not come into contact with metallic objects.



### **Warning**

If the product is improperly disposed of, the following can happen:

- If polymer parts are burnt, poisonous gas are produced which may impair health.
- If batteries are damaged or are heated strongly, they can explode and cause poisoning, burning, corrosion or environmental contamination.
- By disposing of the product irresponsibly you may enable unauthorized persons to use it in contravention of the regulations, exposing themselves and third parties to the risk of severe injury and rendering the environment liable to contamination.
- Improper disposal of silicone oil may cause environmental contamination.

### **Precautions:**

Dispose of the product appropriately in accordance with the regulations in force in your country.

Always prevent access to the product by unauthorized personnel.

---

## **Laser Classification**



### **Warning**

Only Leica Geosystems authorized service workshops are entitled to repair these products.

### **Integrated Distancer, Invisible Laser**

The EDM module built into the product produces an invisible laser beam which emerges from the telescope objective.

The product is a Class 1 Laser Product in accordance with:

- IEC 60825-1 (2001-08): "Safety of Laser Products"
- EN 60825-1:1994 + A11:1996 + A2:2001: "Safety of Laser Products"

Class 1 Laser Products are safe under reasonably foreseeable conditions of operation and are not harmful to the eyes provided that the products are used and maintained in accordance with the instructions.

Description	Value
Maximum radiant power	0.33 mW
Maximum radiant power per pulse	4.12 mW
Pulse duration	800 ps
Pulse repetition frequency	100 MHz
Beam divergence	1.5 mrad x 3 mrad
Measurement uncertainty	± 5%

## Labelling

**Type:** TC....      **Art.No.:** .....

**Power:** 12V/6V ---, 1A max

**Leica Geosystems AG**

**CH-9435 Heerbrugg**

**Manufactured:** .....

**Made in Switzerland**    **S.No.:** .....

*Complies with 21 CFR 1040.10 and 1040.11  
except for deviations pursuant to Laser Notice  
No.50, dated July 26,2001.*

*This device complies with part 15 of the FCC  
Rules. Operation is subject to the following two  
conditions: (1) This device may not cause harm-  
ful interference, and (2) this device must accept  
any interference received, including inter-  
ference that may cause undesired operation.*



Class 1 Laser Product  
according to IEC 60825-1  
(2001-08)

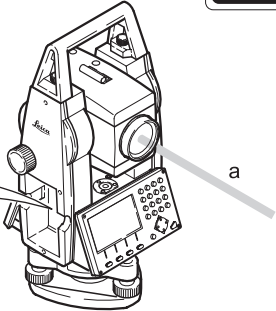

TPS800\_Z69

a) Laser beam

## ***Integrated Distancer, Visible Laser***

As an alternative to the invisible laser, the EDM incorporated into the product produces a visible red laser beam which emerges from the telescope objective.



### **Warning**

The products are Class 3R Laser Products in accordance with:

- IEC 60825-1 (2001-08): "Safety of Laser Products"
- EN 60825-1:1994 + A11:1996 + A2:2001: "Safety of Laser Products"

### **Class 3R Laser Products:**

Direct intrabeam viewing is always hazardous. Avoid direct eye exposure. The accessible emission limit is within five times the accessible emission limits of Class 2 in the wavelength range from 400 nm to 700 nm.

Description	Value
Maximum radiant power	4.75 mW
Maximum radiant power per pulse	59 mW
Pulse duration	800 ps
Pulse repetition frequency	100 MHz
Beam divergence	0.15 mrad x 0.35 mrad
Measurement uncertainty	± 5%



### **Warning**

Direct intrabeam viewing is always hazardous.

### **Precautions:**

Do not stare into the beam or direct it towards other people unnecessarily. These measures are also valid for the reflected beam.



### **Warning**

Looking directly into the reflected laser beam could be dangerous to the eyes when the laser beam is aimed at areas that reflect like a mirror or emit reflections unexpectedly, for example prisms, mirrors, metallic surfaces or windows.

### **Precautions:**

Do not aim at areas that are essentially reflective, such as a mirror, or which could emit unwanted reflections.

Do not look through or beside the optical sight at prisms or reflecting objects when the laser is switched on, in laserpointer or distance measurement mode. Aiming at prisms is only permitted when looking through the telescope.



### **Warning**

The use of Laser Class 3R equipment can be dangerous.

### **Precautions:**

To counteract hazards, it is essential for every user to respect the safety precautions and control measures specified in the standard IEC 60825-1

(2001-08) resp. EN 60825-1:1994 + A11:1996 + A2:2001, within the hazard distance \*); pay particular attention to Section Three "User's Guide".

Following an interpretation of the main points in the relevant section of the standard quoted.

Class 3R Laser Products used on construction sites and outdoors, for example surveying, alignment, levelling:

- a) Only qualified and trained persons should be assigned to install, adjust and operate the laser equipment.
- b) Areas in which these lasers are used should be posted with an appropriate laser warning sign.
- c) Precautions should be taken to ensure that persons do not look directly, with or without an optical instrument, into the beam.

- d) The laser beam should be terminated at the end of its useful beam path and should in all cases be terminated if the hazardous beam path extends beyond the limit (hazard distance \*) of the area in which the presence and activities of personnel are monitored for reasons of protection from laser radiation.
  - e) The laser beam path should be located well above or below eye level wherever practicable.
  - f) When not in use the Laser Product should be stored in a location where unauthorized personnel cannot gain access.
  - g) Precautions should be taken to ensure that the laser beam is not unintentionally directed at mirror-like, specular surfaces for example mirrors, metal surfaces or windows. But, more importantly, at flat or concave mirror-like surfaces.
- \*) The hazard distance is the distance from the laser at which beam irradiance or radiant exposure equals the maximum permissible value to which personnel may be exposed without being exposed to a health risk.

Products with an integrated distancer of laser class 3R this hazard distance is 68 m / 224 ft. At this distance, the laser beam rates as Class 1M, that means direct intrabeam viewing is not hazardous.

## Labelling

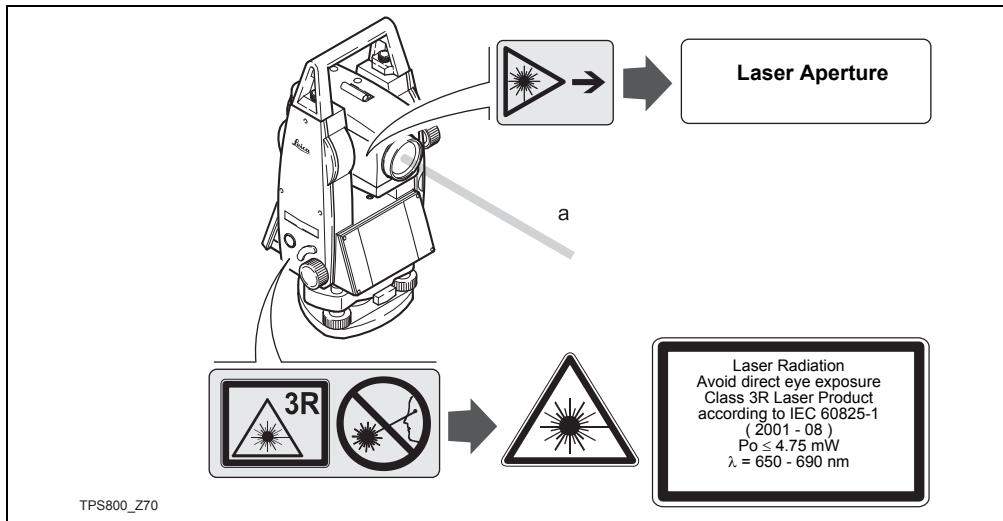

a) Laser beam

## **Electronic Guide Light EGL**

The integrated electronic guide light produces a visible LED beam from the front side of the telescope. Depending on the type of telescope the EGL may be designed differently.

The product is a Class 1 LED product in accordance with:

- IEC 60825-1 (2001-08): "Safety of Laser Products"
- EN 60825-1:1994 + A11:1996 + A2:200): "Safety of Laser Products"

Class 1 LED products are safe under reasonably foreseeable conditions of operation and are not harmful to the eyes provided that the products are used and maintained in accordance with the instructions.

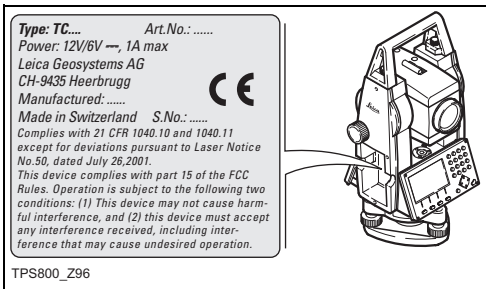

Flashing LED	Yellow	Red
Maximum radiant power	0.28 mW	0.47 mW
Maximum radiant power per pulse	0.75 mW	2.5 mW
Pulse duration	2 x 105 ms	1 x 105 ms
Pulse repetition frequency	1.786 Hz	1.786 Hz
Beam divergence	2.4 °	2.4 °
Measurement uncertainty	± 5%	± 5%

**Class 1 LED Product**  
according to IEC 60825-1  
(2001-08)

**Type:** TC....      **Art.No.:** .....

**Power:** 12V/6V ~~, 1A max

**Leica Geosystems AG**

**CH-9435 Heerbrugg**

**Manufactured:** .....

**Made in Switzerland**    **S.No.:** .....

*Complies with 21 CFR 1040.10 and 1040.11 except for deviations pursuant to Laser Notice No.50, dated July 26,2001.*

*This device complies with part 15 of the FCC Rules. Operation is subject to the following two conditions: (1) This device may not cause harmful interference, and (2) this device must accept any interference received, including interference that may cause undesired operation.*



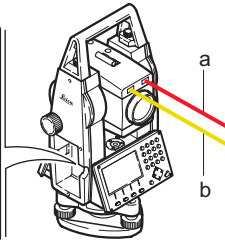

TPS800\_Z72

- a) LED beam red
- b) LED beam yellow

## **Laser plummet**

The laser plummet built into the product produces a visible red laser beam which emerges from the bottom of the product.

The product is a Class 2 Laser Product in accordance with:

- IEC 60825-1 (2001-08): "Safety of Laser Products"
- EN 60825-1:1994 + A11:1996 + A2:2001: "Safety of Laser Products".

Class 2 Laser Products:

Do not stare into the beam or direct it unnecessarily at other persons. Eye protection is normally afforded by aversion responses including the blink reflex.

Description	Value
Maximum radiant power	0.95 mW
Pulse duration	c.w.
Beam divergence	0.16 mrad x 0.6 mrad
Measurement uncertainty	± 5%



### **Warning**

It can be dangerous to look into the beam with optical equipment, for example binoculars or telescopes.

### **Precautions:**

Do not look directly into the beam with optical equipment.

## Labelling

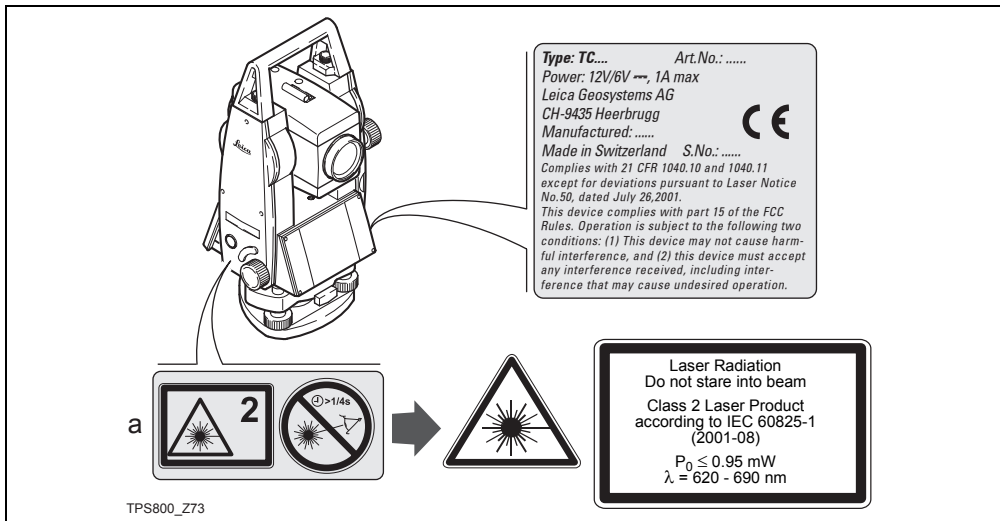

a) Will be replaced by a Class 3R warning label if applicable

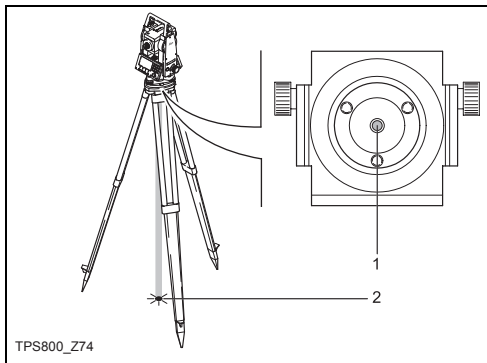

- 1) Laser beam
- 2) Exit for laser beam

---

## **Electromagnetic Compatibility EMC**

The term Electromagnetic Compatibility is taken to mean the capability of the product to function smoothly in an environment where electromagnetic radiation and electrostatic discharges are present, and without causing electromagnetic disturbances to other equipment.



### **Warning**

Electromagnetic radiation can cause disturbances in other equipment.

Although the product meets the strict regulations and standards which are in force in this respect, Leica Geosystems cannot completely exclude the possibility that other equipment may be disturbed.



### **Caution**

There is a risk that disturbances may be caused in other equipment if the product is used in conjunction with accessories from other manufac-

turers, for example field computers, personal computers, two-way radios, non-standard cables or external batteries.

### **Precautions:**

Use only the equipment and accessories recommended by Leica Geosystems. When combined with the product, they meet the strict requirements stipulated by the guidelines and standards. When using computers and two-way radios, pay attention to the information about electromagnetic compatibility provided by the manufacturer.



### **Caution**

Disturbances caused by electromagnetic radiation can result in erroneous measurements. Although the product meets the strict regulations and standards which are in force in this respect, Leica Geosystems cannot completely exclude the possibility that the product may be disturbed by very intense electromagnetic radiation, for example, near radio transmitters, two-way radios or diesel generators.

**Precautions:**

Check the plausibility of results obtained under these conditions.

**Warning**

If the product is operated with connecting cables attached at only one of their two ends, for example external supply cables, interface cables, the permitted level of electromagnetic radiation may be exceeded and the correct functioning of other products may be impaired.

**Precautions:**

While the product is in use, connecting cables, for example product to external battery, product to computer, must be connected at both ends.

---

**FCC Statement, Applicable in U.S.****Warning**

This equipment has been tested and found to comply with the limits for a Class B digital device, pursuant to part 15 of the FCC rules.

These limits are designed to provide reasonable protection against harmful interference in a residential installation.

This equipment generates, uses and can radiate radio frequency energy and, if not installed and used in accordance with the instructions, may cause harmful interference to radio communication.

However, there is no guarantee that interference will not occur in a particular installation.

If this equipment does cause harmful interference to radio or television reception, which can be determined by turning the equipment off and on, the user is encouraged to try to correct the interference by one or more of the following measures:

- Reorient or relocate the receiving antenna.



## Technical Data

### Telescope

- Transit fully
- Magnification: ..... 30x
- Image: ..... upright
- Free Objective aperture: ..... 40 mm
- Focusing: ..... 1.7 m (5.6 ft) to infinity
- Field of view: ..... 1°30' (1.7gon)
- Field of view at 100m ..... 2.6 m

### Angle measurement

- absolute, continuous,
- Updates each 0.3 seconds
- Units selectable  
360° sexagesimal, 400gon,  
360° decimal, 6400 mil, V%, ±V
- Accuracy standard deviation Hz, V  
(acc. to ISO 17123-3)  
TC(R)802 ..... 2" (0.6 mgon)  
TC(R)803 ..... 3" (1.0 mgon)  
TC(R)804 ..... 5" (1.5 mgon)

- Display resolution  
gon ..... 0.0001  
360d ..... 0.0001  
360s ..... 1"  
mil ..... 0.01

### Level sensitivity

- Circular level: ..... 6'/2 mm

### Compensator:

- 2-axis-oil compensator
- Setting range ..... ±4' (0.07 gon)
- Setting accuracy .....  
TC(R)802 ..... 0.5" (0.2 mgon)  
TC(R)803 ..... 1" (0.3 mgon)  
TC(R)805 ..... 1.5" (0.5 mgon)

### Laser plummet

- Location: .....in vertical axis of instrument
- Type: ..... visible red laser class 2
- Carrier wave: ..... 635 nm
- Accuracy: ..... Deviation from  
..... plumbline 1.5 mm  
..... (2 sigma) at 1.5 m  
..... instrument height
- Diameter of laser point: ..... 2.5 mm / 1.5 mm

### Keyboard:

- Tilt angle: .....70°
- optional 2nd keyboard

### Display:

- Backlit
- Heatable ..... (Temp. < -5°C)
- LCD: ..... 280 x 160 Pixel
- 8 lines with 31 characters each

### Type of tribrach:

- Tribrach removable GDF111  
Thread diam.: ..... 5/8"  
..... (DIN 18720 / BS 84)

### Dimensions:

- Instrument: .....  
Height (including tribrach and carrying handle):  
- with tribrach GDF111 .....  
..... 360 mm ± 5 mm
- Width: ..... 207 mm
- Length: ..... 150 mm
- Case: ..... 468x254x355mm  
..... (LxBxH)

### Weight:

(including battery and tribrach)

- with tribrach GDF111 ..... 5,2 kg

### Tilting axis height:

- without tribrach ..... 196 mm
- with tribrach GDF111 ..... 240 mm ± 5 mm

### Power supply:

- Battery GEB111: ..... NiMH  
Voltage: ..... 6V  
Capacity: ..... 2100 mAh
- Battery GEB121: ..... NiMH  
Voltage: ..... 6V  
Capacity: ..... 4200 mAh

- External supply (via serial interface) ..... If an external cable is used, ..... then the voltage range must lie ..... between 11.5V and 14V.

**No. of measurements (angle + distance):**

- GEB111: ..... approx. 4000
- GEB121: ..... approx. 9000

**Temperature range:**

Type	Operating temperature	Storage temperature
TPS800	-20°C to +50°C / -4°F to +122°F	-40°C to +70°C / -40°F to +158°F
Battery internal	-20°C to +50°C / -4°F to +131°F	-40°C to +55°C / -40°F to +131°F

**Automatic corrections:**

- Line-of-sight error ..... Yes
- Vertical-index error..... Yes
- Earth curvature ..... Yes
- Refraction ..... Yes
- Tilt correction ..... Yes

**Recording:**

- RS232 interface ..... Yes
- Internal Memory ..... Yes
- Total capacity ..... 576 KB
- ..... ≈ 10000 data blocks or
- ..... ≈ 16000 fixpoints

**Distance measurement (IR: infrared):**

- Type: .....coaxial infrared laser class 1
- Carrier wave: ..... 780 nm
- Measuring system: ...special frequency system  
..... basis 100 MHz  $\hat{=}$  1.5 m
- Display (least count): ..... 1 mm

EDM measuring program	Accuracy* (Standard deviation acc. to ISO 17123-4)	Time per measurement
IR_Fine	2 mm + 2 ppm	<1 sec.
IR_Fast	5 mm + 2 ppm	<0.5 sec.
Tracking	5 mm + 2 ppm	<0.3 sec.
IR Tape	5 mm + 2 ppm	<0.5 sec

\* Beam interruptions, severe heat shimmer and moving objects within the beam path can result in deviations of the specified accuracy.

**Range: (normal and rapid measurement)**

	Standard prism	3 prisms (GPH3)	360° reflector	Tape 60mm x 60mm	Mini prism	360° Mini prism
1	1800 m (6000 ft)	2300 m (7500 ft)	800 m (2600 ft)	150 m (500 ft)	450 m (1500 ft)	450 m (1500 ft)
2	3000 m (10000 ft)	4500 m (14700 ft)	1500 m (5000 ft)	250 m (800 ft)	800 m (2600 ft)	250 m (800 ft)
3	3500 m (12000 ft)	5400 m (17700 ft)	2000 m (7000 ft)	250 m (800 ft)	1000 m (3500 ft)	250 m (800 ft)

- 1) Strong haze, visibility 5km; or strong sunlight, severe heat shimmer
- 2) Light haze, visibility about 20km; or moderate sunlight, slight heat shimmer
- 3) Overcast, no haze, visibility about 40km; no heat shimmer

**Distance measurement (RL: visible)**

- Type: ..... coaxial visible red laser class 3R
- Carrier wave: ..... 670 nm
- Measuring system.... special frequency system  
..... basis 100 MHz  $\hat{=}$  1.5 m
- Display (least count) ..... 1 mm
- Laser dot size: ..... approx. 7x 14 mm / 20 m  
..... approx. 10 x 20 mm / 50 m

**Distance measurement (with reflector)**

- Range of measurement: ..... from 1000m up
- Display unambiguous: ..... to 12 km

<b>Power: Range (with reflector)</b>		
Atmospheric conditions	Standard-prism	Reflector tape 60 x 60
1	2200 m (7200 ft)	600 m (2000 ft)
2	7500 m (24600 ft)	1000 m (3300 ft)
3	> 10000 m (33000 ft)	1300 m (4200 ft)

- 1) Strong haze, visibility 5km; or strong sunlight, severe heat shimmer
- 2) Light haze, visibility about 20km; or moderate sunlight, slight heat shimmer
- 3) Overcast, no haze, visibility about 40km; no heat shimmer

### Distance measurement (reflectorless)

- Range of measurement:  
Standard ..... 1.5 m to 80 m  
Power ..... 1.5 m to 300 m  
..... (to target plate 710 333)
- Display unambiguous:..... to 760 m
- Prism constant (additive constant):. + 34.4 mm

Power: Range (without reflector)		
Atmospheric conditions	No reflector (white target)*	No reflector (grey, albedo 0.25)
4	140 m (460 ft)	70 m (230 ft)
5	170 m (560 ft)	100 m (330 ft)
6	>170 m (560 ft)	>100 m (330 ft)

- \* Kodak Grey Card used with exposure meter for reflected light
- 4) Object in strong sunlight, severe heat shimmer
  - 5) Object in shade, or sky overcast
  - 6) Day, night and twilight

EDM measuring program	Accuracy** (Standard deviation acc. to ISO 17123-4)	Time per measurement
Short	3 mm + 2 ppm	3.0 sec. +1.0 sec./10m > 30m
Prism	5 mm + 2 ppm	2.5 sec.
Tracking	5 mm + 2 ppm	1.0 sec. +0.3 sec./10m > 30m

\*\* Beam interruptions, severe heat shimmer and moving objects within the beam path can result in deviations of the specified accuracy.

---

## ***Atmospheric correction***

The distance displayed is correct only if the scale correction in ppm (mm/km) which has been entered corresponds to the atmospheric conditions prevailing at the time of the measurement.

The atmospheric correction takes air pressure and air temperature into account.

For utmost precision in distance measurements, atmospheric correction must be determined with 1 ppm accuracy, air temperature to 1°C and air pressure to 3mb accuracy.

## Atmospheric correction in ppm with °C, mb, H (metres) at 60% relative humidity

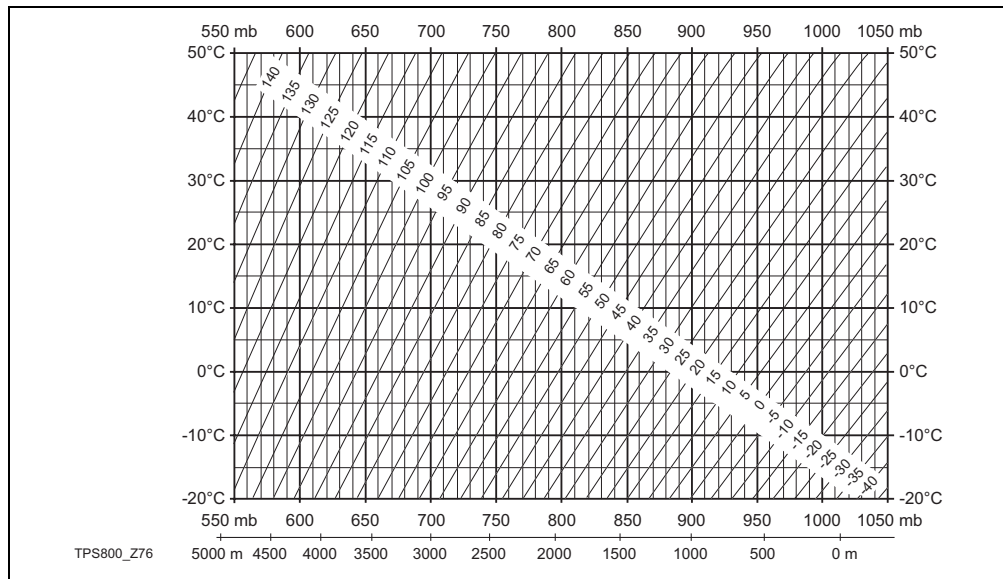

TPS800\_Z76

## Atmospheric correction in ppm with °F, inch Hg, H (feet) at 60% relative humidity

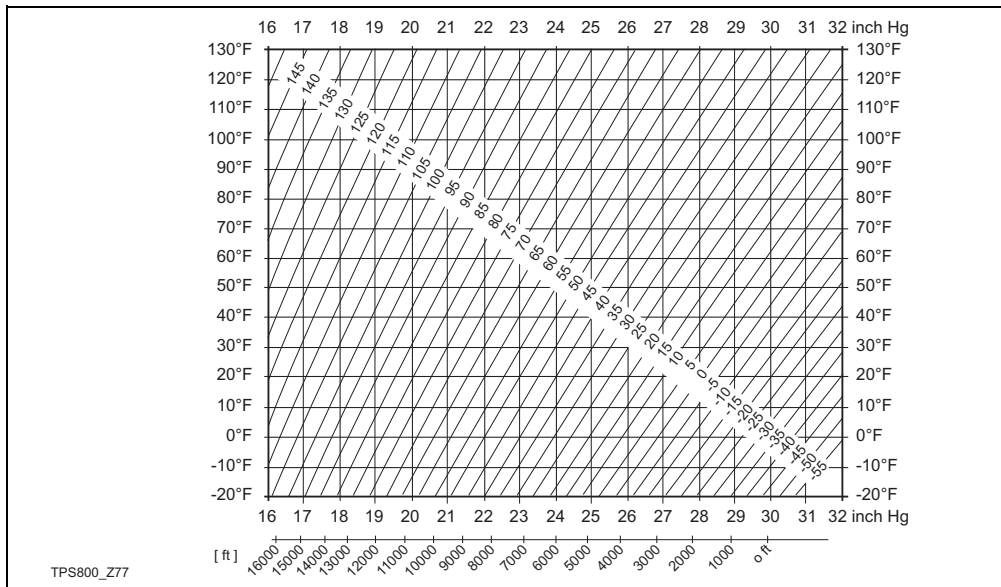

## Reduction formulae

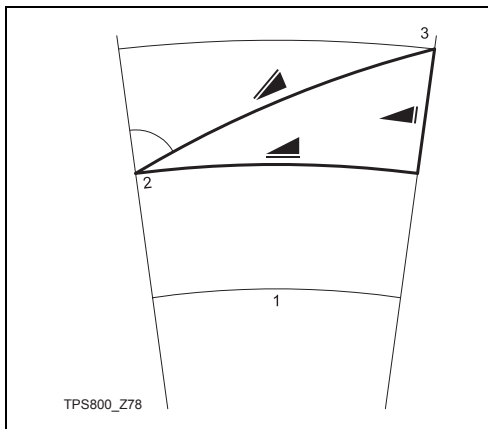

### Height measurement

- 1) Mean sea level
- 2) Instrument
- 3) Reflector

The instrument calculates slope distance, horizontal distance and height difference in accordance with the following formula. Earth curvature and mean refraction coefficient ( $k = 0.13$ ) are taken into account automatically. The calculated horizontal distance relates to the station height, not to the reflector height.

$$\triangle = D_0 \cdot (1 + \text{ppm} \cdot 10^{-6}) + \text{mm}$$

$\triangle$  = displayed slope distance [m]

$D_0$  = uncorrected distance [m]

ppm = scale correction [mm/km]

mm = prism constant [mm]

$$\triangle = Y - A \cdot X \cdot V$$

$$\triangle = X + B \cdot Y_2$$

$\triangle$  = horizontal distance [m]

$\triangle$  = height difference [m]

$$Y = \frac{1}{2} R \cdot |\sin \zeta|$$

$$X = \frac{1}{2} R \cdot \cos \zeta$$

$$\zeta = \text{vertical-circle reading}$$

$$A = \frac{1 - k / 2}{R} = 1.47 \cdot 10^{-7} \text{ [m}^{-1}\text{]}$$

$$B = \frac{1 - k}{2R} = 6.83 \cdot 10^{-8} \text{ [m}^{-1}\text{]}$$

$$k = 0.13$$

$$R = 6.37 \cdot 10^6 \text{ m}$$

# Index

2D-Road .....	50, 77	Battery capacity .....	22
<b>A</b>		Baudrate .....	113
Abbreviations .....	10	Beep .....	92
Additional characters .....	33	Brg .....	72
Adverse uses .....	119	<b>C</b>	
Alphanumeric keys .....	16	Care and Transport .....	116
Angle measurement .....	141	Cartesian Stake out .....	53
Angle Unit .....	94	Centring .....	29
Application default settings .....	44	Character set .....	33
Applications .....	50	Check & Adjust .....	104
Area (plan) .....	73	Check Tie .....	38
ATMOS .....	98	Circular level .....	108
Atmospheric correction .....	147	Cleaning and Drying .....	118
Automatic corrections .....	143	Coarse level-up .....	29
Auto-OFF .....	93	Code Record .....	94
Azimuth .....	72	Codelist .....	101
<b>B</b>		Codelist Manager .....	14
Base Line .....	60, 61	COGO .....	50, 81
Base points .....	60	Collimation axis .....	10
Battery .....	115	Communication parameters .....	113
		Compensator .....	22, 141

Computation procedure .....	55	Electromagnetic Compatibility EMC .....	138
Construction .....	50	Electronic bubble .....	30
Construction application .....	75	Electronic Guide Light EGL .....	133
Contrast .....	90	Endmark .....	113
Coordinate Editor .....	14	Erasing characters .....	32
<b>D</b>		ESC .....	17
Data Exchange Manager .....	14	Extending / editing code .....	87
Data Output .....	92	<b>F</b>	
Data Transfer .....	114	Face I Definition .....	94
Databits .....	113	FCC Statement .....	139
Date .....	115	File Management .....	100
Delete Last Record .....	38	Fine tuning .....	30
Dimensions .....	142	Fixed keys .....	17
Display .....	142	Fixpoints .....	101
Display Heater .....	92	FNC .....	17, 37
Distance measurement .....	18, 144, 145, 146	Free Station .....	54
Distance Unit .....	94	Free-Coding .....	37
<b>E</b>		Function keys .....	16
Edit mode .....	32	<b>G</b>	
EDM Mode .....	95	GSI 8/16 .....	92
EDM Settings .....	95	GSI output format .....	92
EDM type .....	22	GSI output mask .....	92
EGL .....	97	GSI-coding .....	86

GSI-ID's .....	114	Distance - Distance .....	83
Guide Light .....	97	Intersections .....	82
<b>H</b>		Inverse .....	81
Hazards of use .....	123	IR .....	37
Height transfer .....	41	IR/ RL Toggle .....	37
Hidden Point .....	42	IR-Fast .....	95
Horizontal circle .....	10	IR-Fine .....	95
Horizontal direction .....	10	IR-Tape .....	95
Hz Collimation .....	93	IR-Track .....	95
Hz Incrementation .....	92	<b>J</b>	
<b>I</b>		Job .....	100
Initialize Memory .....	102	JPMINI .....	96
Input mode - method 1 .....	32	<b>K</b>	
Inserting / Replacing Battery .....	25	Keyboard .....	142
Inserting characters .....	32	Keypad .....	16
Instr.Temp. ....	115	Known Point .....	45
Integrated distancer .....	127, 129	<b>L</b>	
Interface .....	113	Labelling .....	128, 136, 140
Interface plug connections .....	113	Laser classification .....	127
Intersection		Laser intensity .....	31
Bearing - Bearing .....	82	Laser plummet .....	29, 109, 135, 142
Bearing - Distance .....	83	Laser Pointer .....	97
By Points .....	84		

Laserpointer .....	37
Leica Geo Office Tools .....	13, 89
Level sensitivity .....	141
Level/Plummet .....	37
Light On /Off .....	37
Limits of use .....	120
Line of sight .....	10
Line-of-sight error .....	11, 104

## M

Main Settings .....	40
Manual code input .....	87
Mask 1/2 .....	92
Measurements .....	54, 101
Measuring .....	36
Measuring facilities .....	55
Memory .....	102
MENU .....	17, 23
Menu tree .....	23
Min. Reading .....	93

## N

Navigation keys .....	16
No. of measurements .....	143

## O

Offset	
Distance - Offset .....	84
Extention .....	85
Set Point by ... .....	85
Orientation .....	46
Orthogonal Setout .....	64
Orthogonal Stake out .....	53

## P

PAGE .....	17
Parity .....	113
Permitted uses .....	119
Plumb line .....	11
Pointsearch .....	34
Polar Stake out .....	52
Polygonal Method .....	71
Positioning .....	31
Power supply .....	142
PPM .....	98
Pressure .....	94
Prism Constant .....	97
Prism type .....	96
Programs .....	44

<b>Q</b>			
Quick Code .....	88		
<b>R</b>			
Radial Method .....	71		
Range .....	144, 145, 146		
Recording .....	143		
Recording code block .....	87		
Reduction formulae .....	150		
Reference Arc .....	66		
Reference Line .....	62		
Reference Line/Arc .....	60		
Reflective targets .....	96		
Reflectorless EDM .....	110		
Refraction correction .....	99		
Remote Height .....	74		
Responsibilities .....	121		
Reticle .....	11		
Reticle Illumin. ....	92		
RL .....	37		
RL-Prism .....	96		
RL-Short .....	96		
RL-Track .....	96		
Rod Length .....	42		
		RS232 .....	92
		<b>S</b>	
		Safety Directions .....	119
		SCALE .....	98
		Sector Beep .....	91
		Set manually .....	45
		Setting job .....	44
		Setting Station .....	45
		Settings .....	90
		Signal .....	99
		Signs .....	33
		Softkeys .....	21
		Software Upload .....	14
		Stake out .....	52
		Stake Out Angle .....	70
		Stake Out Arc .....	68
		Stake Out Chord .....	69
		Stake Out Point .....	67
		Standard prism .....	96
		Standing axis .....	10
		Standing axis inclination .....	11
		Start programs .....	44
		Start-up sequence .....	103
		Statistics .....	102

Stopbits .....	113
Storage .....	117
Surveying .....	51
Symbols .....	22
System Info .....	115

## T

Target Offset .....	39
Technical Data .....	141
Technical terms .....	10
Telescope .....	141
Temperature .....	94
Temperature range .....	143
Tie Distance .....	71
Tilt Correction .....	90
Tilting axis .....	10
Tilting axis height .....	142
Time .....	115
Tracking .....	39
Transport .....	116
Traverse .....	82
Tribrach .....	109, 142
Trigger key .....	17, 90
Tripod .....	27, 108

## U

Units .....	37
USER .....	17
USER Key .....	90

## V

Vertical angle .....	10
Vertical circle .....	10
V-Index .....	11, 104
V-Setting .....	90

## W

Weight .....	142
Wildcard search .....	35

## Z

Zenith .....	11
Zenith angle .....	10

**Leica Geosystems AG, Heerbrugg, Switzerland, has been certified as being equipped with a quality system which meets the International Standards of Quality Management and Quality Systems (ISO standard 9001) and Environmental Management Systems (ISO standard 14001).**



**Total Quality Management-  
Our commitment to total customer  
satisfaction.**

*Ask your local Leica dealer for more  
information about our TQM program.*

742617-1.0.0en

Printed in Switzerland - Copyright Leica Geosystems AG,  
Heerbrugg, Switzerland 2004  
Original text

**Leica**  
**Geosystems**

**Leica Geosystems AG  
CH-9435 Heerbrugg  
(Switzerland)**

**Phone +41 71 727 31 31**

**Fax +41 71 727 46 73**

**[www.leica-geosystems.com](http://www.leica-geosystems.com)**